

# ANDERSON GREENWOOD

The Safety Selector Valve is designed specifically to function as an effective “switchover” device.

## Features

- Designed to provide a safe, efficient method of switching from an active pressure relief device to a standby, maintaining system overpressure protection regardless of Safety Selector Valve position.
- Provides high  $C_v$  values, resulting in less than 3% pressure drop to the active PRV inlet, when used with the largest API orifice available in a given valve size, in accordance with the recommendations of API RP520 Part II and ASME Section VIII, Division 1, Appendix M, helping reduce the possibility of destructive chatter of the PRV.
- Requires only one minimally sized penetration into the vessel or pipe, reducing costs.
- Reduces field installation costs and space requirements through preassembled and compact design.
- Provides process isolation of standby pressure relief device.
- Allows pressure relief device maintenance without process shutdown.
- A bleed valve is provided under each safety relief device as an effective and safe means of venting entrapped process under an isolated pressure relief valve prior to removal for maintenance.
- Bright red indicator for positive indication of active pressure relief device.
- Meets all mandatory requirements of ASME Section VIII, Division 1, UG-135 (b).
- Foolproof provisions for dual padlocking in either pressure relief valve position, in accordance with the recommendations of ASME Section VIII.
- Packing design has been tested to ASTM E427, Method A halogen leak test, reducing probability of fugitive emissions.
- No seat lapping required for maintenance. Only recommended spare parts are soft goods which reduces cost of ownership.
- Meets standard temperature applications from cryogenic to +800°F [427°C].
- Offers materials of construction compatible with pressure relief devices. Duplex and 6MO material available.
- Helps deliver a reduced number of leak points to atmosphere, reducing probability of fugitive emissions.



- Isolates a standby pressure relief valve in accordance with joint recommendation of API Subcommittee on Pressure Relieving Systems and Subcommittee on Refinery Inspection.
- Type approval by Det Norske Veritas (DNV).
- Simplicity of operation with built-in seat equalization and no special tools minimizes total time to operate valve.

## Recommended Specifications

Changeover device inlet connection is to be the same size and rating as the pressure relief valve inlets.

- Pressure drop through the changeover device's active side cannot exceed 3% with pressure relief valve fully open.
- Changeover device is to have external indicator, showing which side is active.
- Provisions for double padlocking in either position are required.
- A valve bleed port must be located under each pressure relief valve connection for pressure venting under the inactive pressure relief valve.

### Operation

#### Traditional Dual Pressure Relief Device Systems

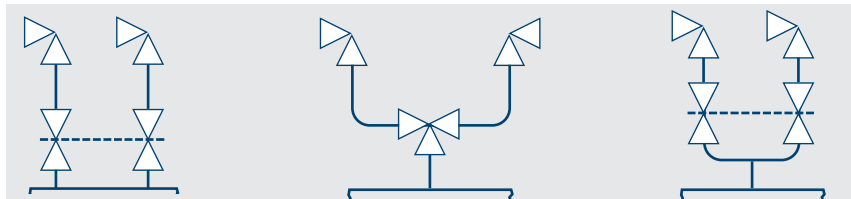

**Interlocking Block Valve with Two Vessel Penetrations**

**3-Way Block Valve with Pipe Elbows**  
(see Pressure Drop Comparison Below)

**Interlocking Block Valve with Pipe Tee and Elbows**

Using API Standard 526 direct acting spring loaded valves, the comparative pressure drop through the Safety Selector Valve versus the same size 3-way ball valve is as follows:

	2" 2J3	3" 3L4	4" 4P6	6" 6R8	8" 8T10
SSV	1.50%	0.86%	1.42%	1.37%	1.31%
3-Way Ball	6.36%	5.65%	9.30%	10.6%	8.69%

#### Dual Pressure Relief Device Systems

Anderson Greenwood developed the Safety Selector Valve in response to the growing demand for cost-effective, dual pressure relief valve and/or rupture disc installations in today's process industries. The Safety Selector Valve is designed specifically to function as an effective "switchover" device that permits routine or emergency servicing of redundant pressure relief devices with no process interruption, thus providing continuous system overpressure protection. Until recently, bulky and expensive piping fabrications or total shutdown were the only methods for servicing the pressure relief devices. These systems required either two separate vessel penetrations with mechanically linked block valves or a 3-way block valve that commonly resulted in high inlet pressure loss, excessive turbulence to the active pressure relief device and multiple leak points.

The Anderson Greenwood Safety Selector Valve solves these problems. It is easy to install, requiring only one vessel penetration in the same size as the pressure relief valve inlet. The unique design provides less than 3% pressure drop to the active pressure relief valve inlet when used with the largest API orifice available in a given valve size, in accordance with API RP520, Part II and ASME Section VIII guidelines.

### Applications

#### Liquid/Two Phase Service

Safety selector valves can be used in gas/vapor, steam, or liquid service. Safety selector valves can also be used in two phase service. The picture on the left is of an Anderson Greenwood Series 400 pilot valve relieving on liquid only. The picture on the right shows the same valve transitioning to two phase flow as gas is becoming entrained in the relief stream.

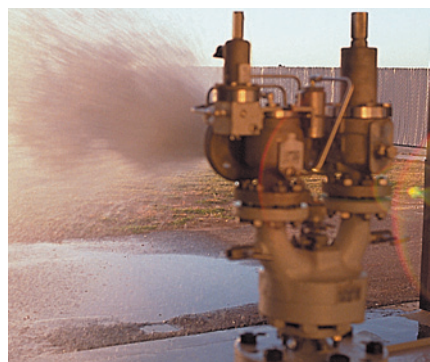

#### Section I Steam Service

##### Safety Selector Valves can be utilized for certain Section I Boiler applications.

Per ASME Section I Boiler and Pressure Vessel Code Case 2254, a switchover valve such as the Safety Selector Valve can be installed to provide a back-up safety valve for boilers with a maximum allowable working pressure (MAWP) of 800 psig or less.



The code case requires that the following criteria be met by the switchover device:

Positive locking	Yes
External bleed valves	Yes
Certified $C_v$ values	Yes

The Safety Selector Valve will provide the highest flow efficiency ( $C_v$ ) of any other switchover device in the same nominal pipe size. These  $C_v$  values allow the Safety Selector Valve to be used with most manufacturers' flanged Section I Boiler valves and meet the code case requirements. Please provide the model number and set pressure of the safety valves to be used to ensure complete compliance with the code case.

**1 1/2" to 10" Sizes**

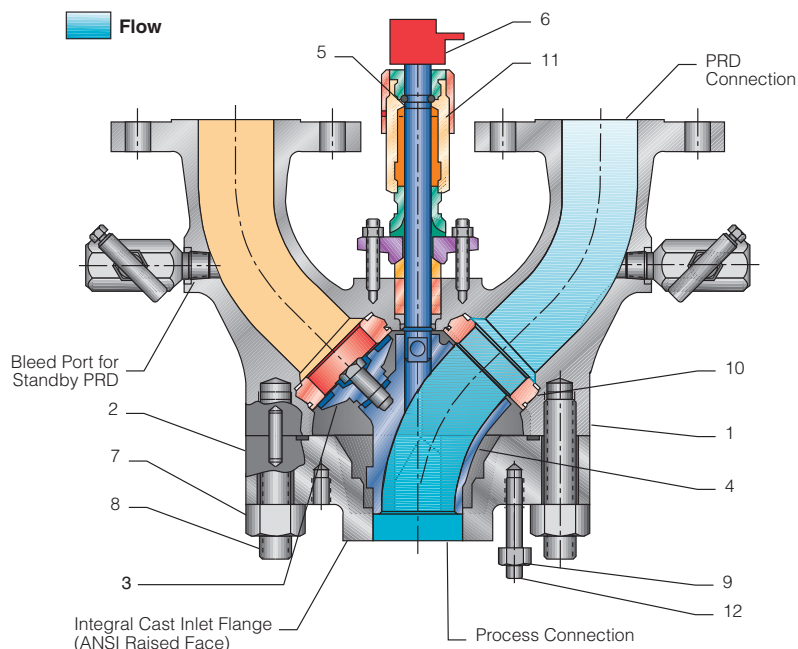

**Materials of Construction**

Description	Material	
	CS	SS
1. Body	A216-WCB CS	A351-CF8M SS
2. Base	A216-WCB CS	A351-CF8M SS
3. Isolation Disc	17-4 SS	17-4 SS
4. Rotor	A351-CF8M SS	A351-CF8M SS
5. Index Shaft	17-4 SS	17-4 SS
6. Indicator	A351-CF8M SS	A351-CF8M SS
7. Body/Base Nut	SA194-2H CS	SA194-8M SS
8. Body/Base Stud	SA193-B7 CS	SA193-B8M SS
9. Process Connection Nut	SA194-2H CS	SA194-8M SS
10. Seat	A479-316 SS or A351-CF8M SS	A479-316 SS or A351-CF8M SS
11. Retraction Bushing	17-4 SS	17-4 SS
12. Process Connection Stud	SA193-B7 CS	SA193-B8M SS

**1" Size Only**

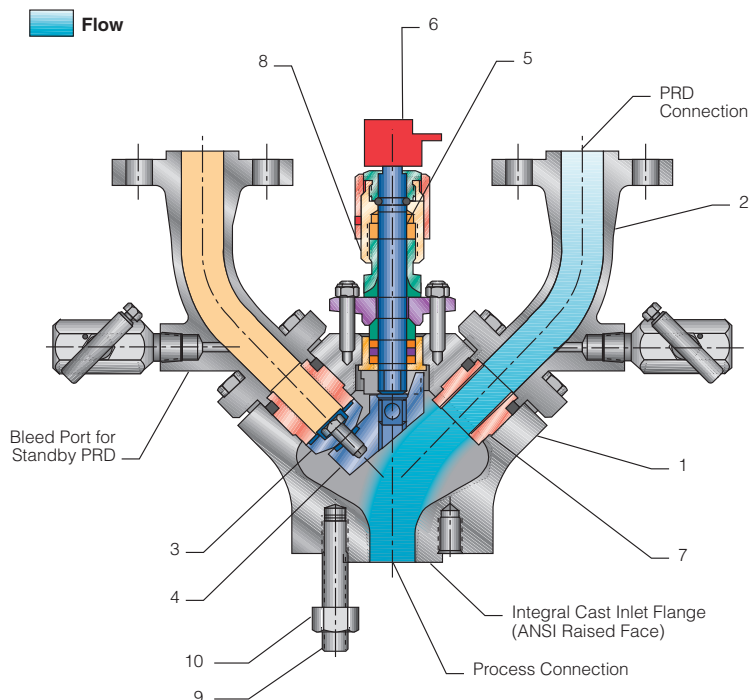

**Materials of Construction**

Description	Material	
	CS	SS
1. Body	A216-WCB CS	A351-CF8M SS
2. Elbow	A216-WCB CS	A351-CF8M SS
3. Isolation Disc	17-4 SS	17-4 SS
4. Rotor	A351-CF8M SS	A351-CF8M SS
5. Index Shaft	17-4 SS	17-4 SS
6. Indicator	A351-CF8M SS	A351-CF8M SS
7. Seat	A479-316 SS or A351-CF8M SS	A479-316 SS or A351-CF8M SS
8. Retraction Bushing	17-4 SS	17-4 SS
9. Process Connection Stud	SA193-B7 CS	SA193-B8M SS
10. Process Connection Nut	SA194-2H CS	SA194-8M SS

### Safety Selector Valve Specifications

#### Specifications

Size	Flow Efficiency (C <sub>v</sub> )	Maximum Pressure Rating psig [barg] (@ 100°F) [37.8°C]		Soft Goods Maximum Temperature Rating °F [°C]		
		CS Body	SS Body	Teflon®	PEEK/ GRAFOIL®	GRAFOIL®
1"	34	6170 [425.5]	6000 [413.8]	400 [204.4]	600 [315]	800 [426.7]
1.5"	121	6170 [425.5]	6000 [413.8]	400 [204.4]	600 [315]	800 [426.7]
2"	255	6170 [425.5]	6000 [413.8]	400 [204.4]	600 [315]	800 [426.7]
3"	612	2220 [153.1]	2160 [150.0]	400 [204.4]	600 [315]	800 [426.7]
4"	1061	2220 [153.1]	2160 [150.0]	400 [204.4]	600 [315]	800 [426.7]
6"	2713	1480 [102.1]	1440 [99.3]	400 [204.4]	600 [315]	800 [426.7]
8"	4512	1480 [102.1]	1440 [99.3]	400 [204.4]	600 [315]	800 [426.7]
10"	6930	740 [51.0]	720 [49.6]	400 [204.4]	600 [315]	800 [426.7]

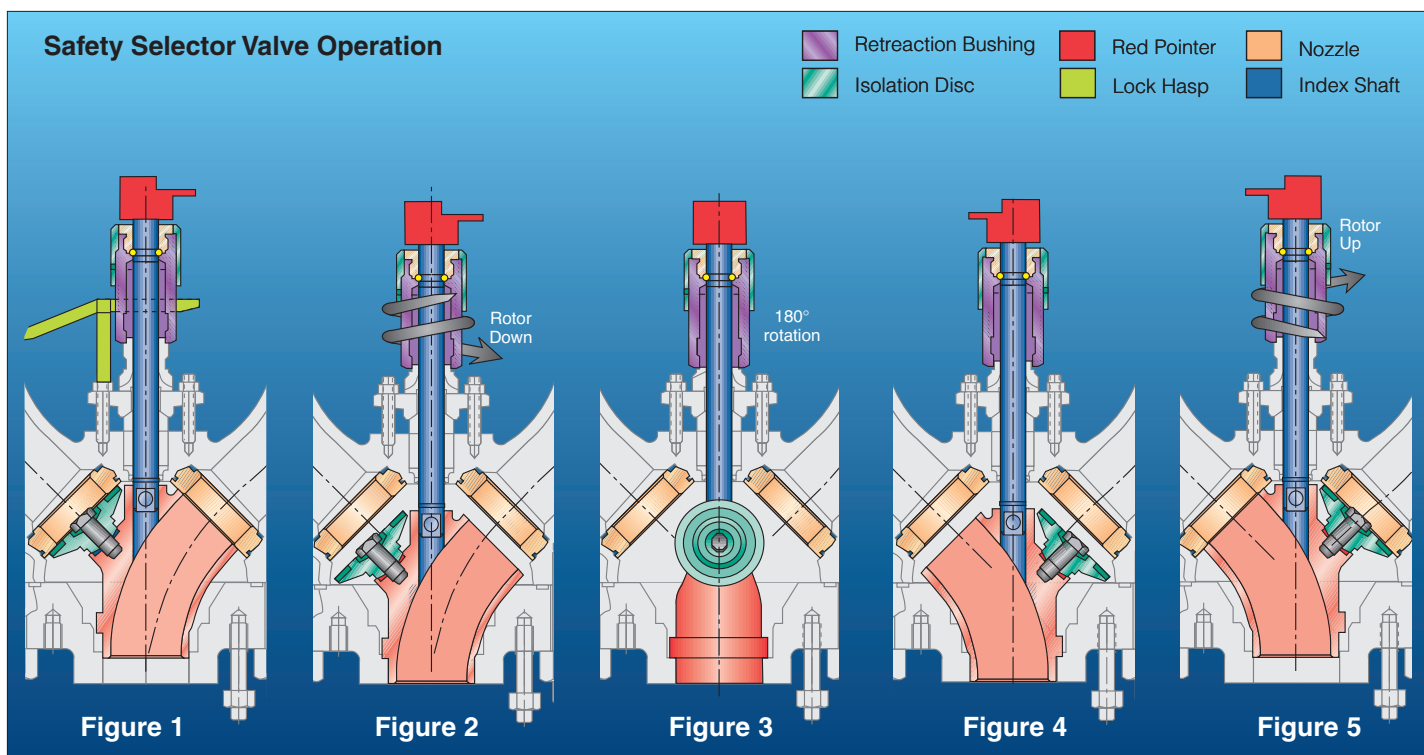

The Anderson Greenwood Safety Selector Valve body houses a uniquely designed switching mechanism. The internal rotor smoothly diverts flow to either pressure relief device. Either direct spring operated valves, pilot operated valves or rupture discs may be used. The inactive device is totally isolated by external adjustment (Figures 1 and 5). To begin switchover, the

padlocks or seals are removed, the lock hasp is opened, and the retraction bushing is rotated to its stop (Figure 2). This lowers the isolation disc from nozzle under the standby valve and temporarily “floats” it in the main valve cavity. The index shaft is then rotated 180 degrees to the alternate channel (Figures 3 and 4). The retraction bushing is then raised, securely seating

the isolation disc beneath the valve to be taken out of service (Figure 5). A red pointer indicates which device is in service and double padlocking provisions allow the Safety Selector Valve to be locked in either position. The padlocks or car seals can only be installed with the internals in the proper position. *No special tools are necessary for switching.*

**Tandem Safety Selector Valve**

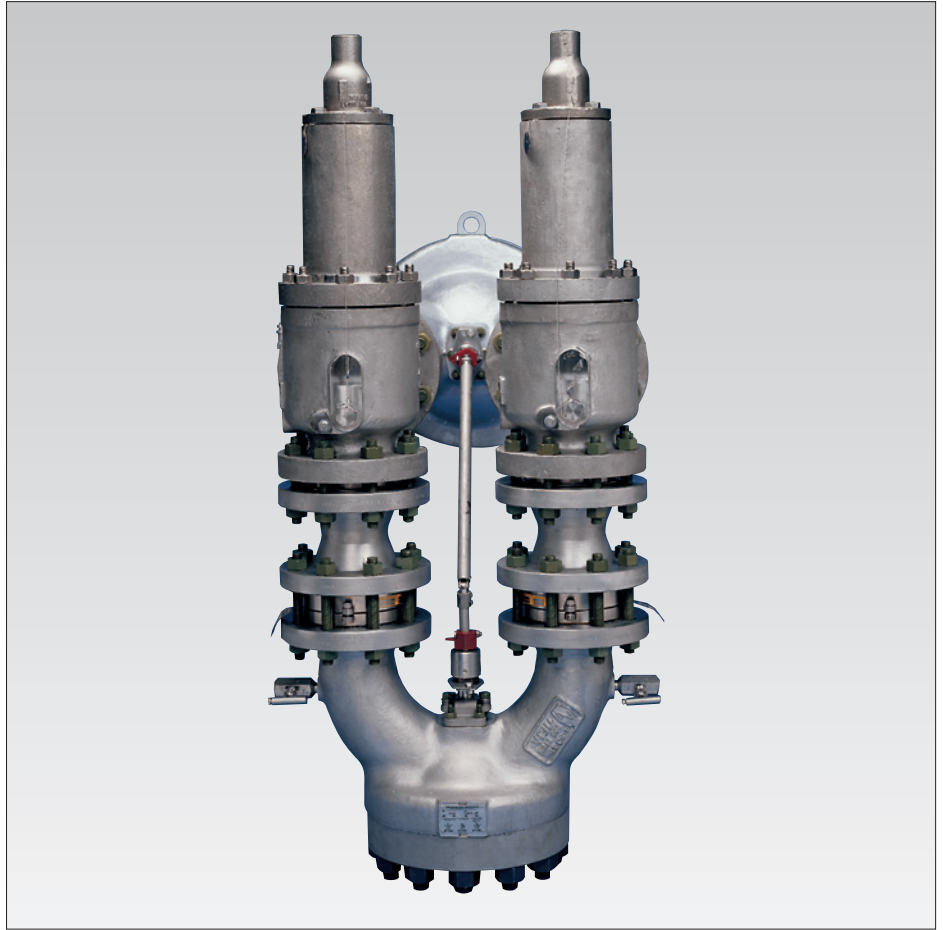

**Conventional Method**

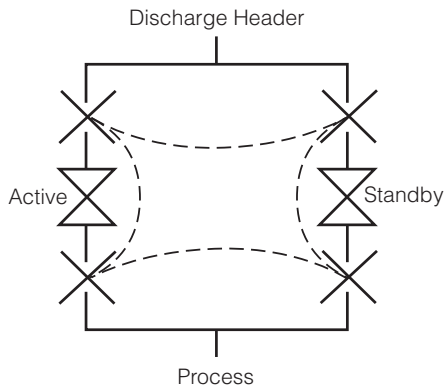

**Anderson Greenwood Tandem Safety Selector Valve**

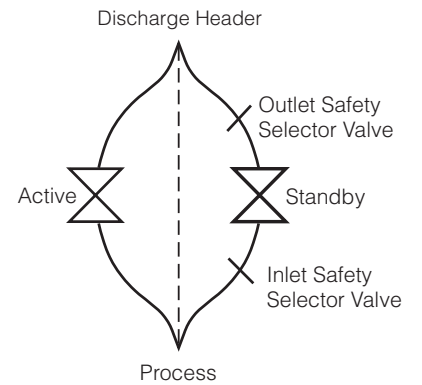

**Customer Fabricated**

- Mechanical linkage or Keys and Locks between block valves
- X Block Valves
- △ Relief Valves

**Anderson Greenwood Furnished**

- Interlocking Mechanism
- △ Relief Valves
- / Isolation Disc
- ∪ Selector Valve

### Tandem Safety Selector Valve



The Anderson Greenwood Tandem Safety Selector Valve System allows for simultaneous selection of pressure relief valve and corresponding discharge outlet piping of dual pressure relief devices discharging into a closed header system.

These redundant pressure relief device systems can be heavy and bulky, require significant field fabrication, installation time and expense, and can be difficult and confusing to operating personnel.

The Anderson Greenwood Tandem Safety Selector Valve System provides a better, safer alternative.

Redundant pressure relief valves discharging into a closed header system utilize all of the inherent advantages of the Anderson Greenwood Safety Selector Valves. The two pressure relief valves, two safety selector valves, and a simple linkage are pre-assembled at the factory. Only one flanged inlet and one flanged outlet connection are required to be made up in the field. The linkage between the inlet and outlet pressure relief valves is simple, foolproof, and provides positive and simultaneous switching of the Selector Valves.

End your concern about closing off the wrong outlet block valve. Overpressure protection is available 100% of the time.

#### Advantages

- **Enhanced Safety:** Eliminates the possibility of inadvertently closing a block valve either upstream or downstream of the intended active pressure relief valve.
- Overpressure protection of process maintained at all times during switchover.
- Compact and low weight.
- Lower installation costs than with conventional methods. No field fabrication or multiple crane lifts required.
- Single, minimally sized penetration into vessel, single discharge header connection.
- Anderson Greenwood offers a completely coordinated, tested, and assembled package consisting of the pressure relief devices and inlet and outlet Safety Selector Valves. The installed interconnecting linkage ensures that both inlet and outlet Safety Selector Valves switch simultaneously.
- **Ease of Engineering:** No need to use oversized piping and valves to prevent excessive pressure loss. Safety Selector Valves in tandem are of the same line size as the pressure relief valve flanges.
- Assurance of less than 3% pressure drop to the pressure relief valve inlet when used with the largest API orifice available in a given valve size.

## Dimensions and Weights

Single Active Safety Selector Valve			1" [25]	1 1/2" [40]	2" [50]	3" [80]	4" [100]	6" [150]	8" [200]*	10" [254]
ANSI Class	Dimensions and Weights									
150#	A RF	11.07 [281]	12.07 [307]	11.70 [297]	13.26 [337]	16.13 [410]	20.17 [512]	24.69 [627]	30.25 [768]	
	A RTJ	11.07 [281]	12.26 [311]	11.89 [302]	13.45 [342]	16.32 [415]	20.37 [517]	24.88 [632]	30.25 [768]	
	B	10.31 [262]	10.31 [262]	10.31 [262]	12.00 [305]	14.50 [368]	17.00 [432]	19.50 [495]	19.50 [495]	
	D "Max."	19.50 [495]	19.50 [495]	19.50 [495]	22.44 [570]	26.06 [662]	32.13 [816]	36.97 [939]	40.75 [1035]	
	Weight	52 (24)	122 (55)	115 (52)	169 (77)	267 (121)	594 (269)	989 (449)	1490 (676)	
300#	A RF	11.07 [281]	12.45 [316]	11.95 [297]	13.70 [348]	16.63 [442]	21.17 [538]	25.69 [653]	30.25 [768]	
	A RTJ	11.07 [281]	12.64 [321]	12.20 [310]	13.95 [354]	16.88 [429]	21.43 [544]	25.94 [659]	30.25 [768]	
	B	10.31 [262]	10.31 [262]	10.31 [262]	12.00 [305]	14.50 [368]	17.00 [432]	19.50 [495]	19.50 [495]	
	D "Max."	19.50 [495]	19.50 [495]	19.50 [495]	22.44 [570]	26.06 [662]	32.13 [816]	36.97 [939]	40.75 [1035]	
	Weight	52 (24)	127 (58)	118 (54)	178 (81)	287 (130)	635 (288)	1043 (473)	1550 (703)	
600#	A RF	11.07 [281]	12.57 [319]	12.21 [310]	14.08 [358]	17.57 [451]	22.36 [568]	26.25 [667]	-	-
	A RTJ	11.07 [281]	12.57 [319]	12.27 [312]	14.14 [359]	17.63 [488]	22.43 [570]	26.31 [668]	-	-
	B	10.31 [262]	10.31 [262]	10.31 [262]	12.00 [305]	14.50 [368]	17.00 [432]	19.50 [495]	-	-
	D "Max."	19.50 [495]	19.50 [495]	19.50 [495]	22.44 [570]	26.06 [662]	32.13 [816]	36.97 [939]	-	-
	Weight	52 (24)	129 (59)	122 (55)	184 (83)	311 (141)	699 (317)	1127 (511)	-	-
900#	A RF	15.00 [381]	13.69 [348]	15.07 [383]	18.26 [464]	21.90 [556]	-	-	-	-
	A RTJ	15.00 [381]	13.69 [348]	15.07 [383]	18.38 [467]	22.02 [559]	-	-	-	-
	B	12.00 [305]	12.00 [305]	12.00 [305]	12.00 [305]	14.50 [368]	-	-	-	-
	D "Max."	21.54 [547]	21.54 [547]	21.54 [547]	22.44 [570]	26.06 [662]	-	-	-	-
	Weight	153 (70)	155 (70)	174 (79)	235 (107)	381 (173)	-	-	-	-
1500#	A RF	15.00 [381]	13.69 [348]	15.07 [383]	-	-	-	-	-	-
	A RTJ	15.00 [381]	13.69 [348]	15.07 [383]	-	-	-	-	-	-
	B	12.00 [305]	12.00 [305]	12.00 [305]	-	-	-	-	-	-
	D "Max."	21.54 [547]	21.54 [547]	21.54 [547]	-	-	-	-	-	-
	Weight	153 (70)	155 (70)	174 (79)	-	-	-	-	-	-
2500#	A RF	18.62 [473]	18.60 [472]	15.07 [383]	-	-	-	-	-	-
	A RTJ	18.62 [473]	18.60 [472]	15.07 [383]	-	-	-	-	-	-
	B	12.00 [305]	12.00 [305]	12.00 [305]	-	-	-	-	-	-
	D "Max."	21.54 [547]	21.54 [547]	21.54 [547]	-	-	-	-	-	-
	Weight	173 (79)	205 (93)	195 (89)	-	-	-	-	-	-

\* For Crosby brand JOS-E/JBS-E/JLT-E direct spring valves, refer to table below.

JOS-E/JBS-E – T and T2 Orifice PRVs			8" [200]
ANSI Class	Dimensions and Weights		
150#	A RF	36.06 [916]	
	A RTJ	36.25 [921]	
	B	23.50 [597]	
	D "Max."	36.97 [939]	
	Weight	1089 (494)	
300#	A RF	37.06 [941]	
	A RTJ	37.31 [948]	
	B	23.50 [597]	
	D "Max."	36.97 [939]	
	Weight	1178 (534)	



- Notes:**
1. D Maximum dimension is for threaded hand valves.
  2. Dimensions in inches [ ] in millimeters.  
Weights in pounds ( ) in kilograms.

### Dimensions and Weights – Tandem Safety Selector Valve with Pilot Operated Valves

#### Tandem Safety Selector Valve with API 526 Pilot Operated PRVs

API Orifice	Inlet by Outlet Size	Inlet Flange		Outlet Flange		Tandem SSV Envelope Dimensions, inches [mm]	
		ANSI Pressure Class	Face Type	ANSI Pressure Class	Face Type	A	B
D/E/F	1 x 2	150	RF	150	RF	15.26 [387]	16.26 [413]
D/E/F	1 x 2	300	RF	150	RF	15.51 [394]	16.26 [413]
D/E/F	1 x 2	600	RF	150	RF	15.51 [394]	16.26 [413]
D/E/F	1 x 2	600	RJ	150	RF	15.61 [396]	16.26 [413]
D/E/F	1 x 2	900	RF	300	RF	20.00 [508]	20.98 [533]
D/E/F	1 x 2	900	RJ	300	RF	20.10 [510]	20.98 [533]
D/E/F	1 x 2	1500	RF	300	RF	20.00 [508]	20.98 [533]
D/E/F	1 x 2	1500	RJ	300	RF	20.10 [510]	20.98 [533]
D/E/F	1 x 2	2500	RF	300	RF	23.62 [600]	20.98 [533]
D/E/F	1 x 2	2500	RJ	300	RF	23.72 [602]	20.98 [533]
D/E/F	1 1/2 x 2	150	RF	150	RF	17.01 [432]	16.51 [419]
D/E/F	1 1/2 x 2	300	RF	150	RF	17.39 [442]	16.51 [419]
D/E/F	1 1/2 x 2	600	RF	150	RF	17.51 [445]	16.51 [419]
D/E/F	1 1/2 x 2	600	RJ	150	RF	17.61 [447]	16.51 [419]
D/E/F	1 1/2 x 2	900	RF	300	RF	19.63 [498]	21.73 [552]
D/E/F	1 1/2 x 2	900	RJ	300	RF	19.73 [501]	21.73 [552]
D/E/F	1 1/2 x 2	1500	RF	300	RF	19.63 [498]	21.73 [552]
D/E/F	1 1/2 x 2	1500	RJ	300	RF	19.73 [501]	21.73 [552]
D/E/F	1 1/2 x 2	2500	RF	300	RF	24.54 [623]	21.73 [552]
D/E/F	1 1/2 x 2	2500	RJ	300	RF	24.64 [626]	21.73 [552]
G/H	1 1/2 x 3	150	RF	150	RF	17.26 [438]	22.42 [569]
G/H	1 1/2 x 3	300	RF	150	RF	17.64 [448]	22.42 [569]
G/H	1 1/2 x 3	600	RF	150	RF	17.76 [451]	22.42 [569]
G/H	1 1/2 x 3	600	RJ	150	RF	17.86 [454]	22.42 [569]
G/H	1 1/2 x 3	900	RF	300	RF	20.13 [511]	24.29 [617]
G/H	1 1/2 x 3	900	RJ	300	RF	20.23 [514]	24.29 [617]
G/H	1 1/2 x 3	1500	RF	300	RF	20.13 [511]	24.29 [617]
G/H	1 1/2 x 3	1500	RJ	300	RF	20.23 [514]	24.29 [617]
G/H	1 1/2 x 3	2500	RF	300	RF	25.04 [636]	20.51 [521]
G/H	1 1/2 x 3	2500	RJ	300	RF	25.10 [637]	20.51 [521]

continues on page 9

**Note:**

1. Calculated using 1/16" thick gaskets for RF connections and the spacing listed in Table 5 of ANSI B16.5 for RJ connections.

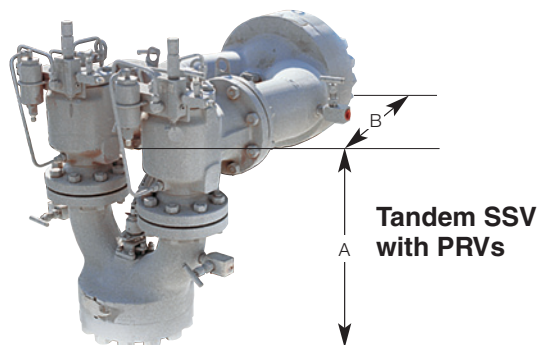

Dimensions and Weights – Tandem Safety Selector Valve with Pilot Operated Valves

Tandem Safety Selector Valve with API 526 Pilot Operated PRVs

API Orifice	Inlet by Outlet Size	Inlet Flange		Outlet Flange		Tandem SSV Envelope Dimensions, inches [mm]	
		ANSI Pressure Class	Face Type	ANSI Pressure Class	Face Type	A	B
G/H/J	2 x 3	150	RF	150	RF	17.14 [435]	22.42 [569]
G/H/J	2 x 3	300	RF	150	RF	17.39 [442]	22.42 [569]
G/H/J	2 x 3	600	RF	150	RF	17.65 [448]	22.42 [569]
G/H/J	2 x 3	600	RJ	150	RF	17.84 [453]	22.42 [569]
G/H/J	2 x 3	900	RF	300	RF	21.69 [551]	24.29 [617]
G/H/J	2 x 3	900	RJ	300	RF	21.75 [553]	24.29 [617]
G/H/J	2 x 3	1500	RF	300	RF	21.69 [551]	20.51 [521]
G/H/J	2 x 3	1500	RJ	300	RF	21.75 [553]	20.51 [521]
G/H/J	2 x 3	2500	RF	300	RF	22.13 [562]	20.51 [521]
G/H/J	2 x 3	2500	RJ	300	RF	22.19 [564]	20.51 [521]
J/K/L	3 x 4	150	RF	150	RF	19.45 [494]	28.38 [721]
J/K/L	3 x 4	300	RF	150	RF	19.89 [505]	28.38 [721]
J/K/L	3 x 4	600	RF	150	RF	20.52 [521]	28.38 [721]
J/K/L	3 x 4	600	RJ	150	RF	14.33 [364]	28.38 [721]
J/K/L	3 x 4	900	RF	300	RF	25.82 [656]	29.63 [752]
J/K/L	3 x 4	900	RJ	300	RF	26.04 [661]	29.63 [752]
L/M/N/P	4 x 6	150	RF	150	RF	23.94 [608]	35.57 [904]
L/M/N/P	4 x 6	300	RF	150	RF	24.44 [621]	35.57 [904]
L/M/N/P	4 x 6	600	RF	150	RF	25.38 [645]	35.57 [904]
L/M/N/P	4 x 6	600	RJ	150	RF	25.57 [649]	35.57 [904]
L/M/N/P	4 x 6	900	RF	300	RF	31.77 [807]	37.51 [953]
L/M/N/P	4 x 6	900	RJ	300	RF	31.99 [813]	37.51 [953]
P	4 x 6	600	RF	150	RF	27.44 [697]	36.51 [927]
P	4 x 6	600	RJ	150	RF	27.63 [702]	36.51 [927]
Q/R	6 x 8	150	RF	150	RF	29.67 [754]	42.53 [1080]
Q/R	6 x 8	300	RF	150	RF	30.67 [779]	42.53 [1080]
Q/R	6 x 8	600	RF	150	RF	32.11 [816]	42.53 [1080]
Q/R	6 x 8	600	RJ	150	RF	32.31 [821]	42.53 [1080]
T	8 x 10	150	RF	150	RF	35.63 [905]	34.31 [871]
T	8 x 10	300	RF	150	RF	36.63 [930]	34.31 [871]
T	8 x 10	600	RF	150	RF	38.00 [965]	34.31 [871]
T	8 x 10	600	RJ	150	RF	38.19 [970]	34.31 [871]

Note:

1. Calculated using 1/16" thick gaskets for RF connections and the spacing listed in Table 5 of ANSI B16.5 for RJ connections.

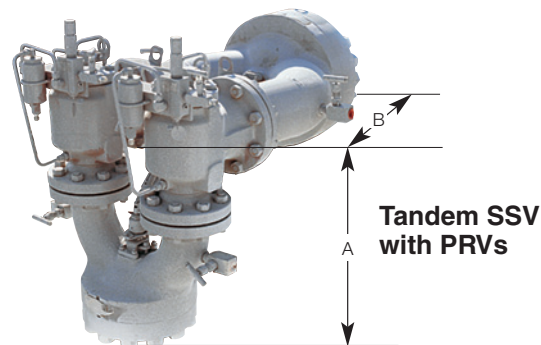

### Dimensions and Weights – Tandem Safety Selector Valve with Direct Spring Valves

#### Tandem Safety Selector Valve with API 526 Direct Spring Operated PRVs

API Orifice	Inlet by Outlet Size	Inlet Flange		Outlet Flange		Tandem SSV Envelope Dimensions, inches [mm]	
		ANSI Pressure Class	Face Type	ANSI Pressure Class	Face Type	A	B
D/E	1 x 2	150	RF	150	RF	15.26 [387]	16.26 [413]
D/E	1 x 2	300	RF	150	RF	15.26 [387]	16.26 [413]
D/E	1 x 2	600	RF	150	RF	15.26 [387]	16.26 [413]
D/E	1 x 2	600	RJ	150	RF	15.36 [390]	16.26 [413]
D/E	1½ x 2	900	RF	300	RF	17.88 [454]	21.73 [552]
D/E	1½ x 2	900	RJ	300	RF	17.98 [457]	21.73 [552]
D/E	1½ x 2	1500	RF	300	RF	17.88 [454]	21.73 [552]
D/E	1½ x 2	1500	RJ	300	RF	17.98 [457]	21.73 [552]
D/E/F	1½ x 3	2500	RF	300	RF	24.16 [614]	20.76 [527]
D/E/F	1½ x 3	2500	RJ	300	RF	24.22 [615]	20.76 [527]
E/F/G	1½ x 3	900	RF	300	RF	18.63 [473]	20.26 [515]
E/F/G	1½ x 3	900	RJ	300	RF	18.73 [476]	20.26 [515]
F	1½ x 2	150	RF	150	RF	17.01 [432]	16.51 [419]
F	1½ x 2	300LW	RF	150	RF	17.39 [442]	16.51 [419]
F	1½ x 2	300	RF	150	RF	17.39 [442]	17.76 [451]
F	1½ x 2	600	RF	150	RF	17.51 [445]	17.76 [451]
F	1½ x 2	600	RJ	150	RF	17.61 [447]	17.76 [451]
F	1½ x 3	1500	RF	300	RF	18.63 [473]	20.26 [515]
F	1½ x 3	1500	RJ	300	RF	18.73 [476]	20.26 [515]
G	1½ x 3	600	RF	150	RF	17.51 [445]	23.54 [598]
G	1½ x 3	600	RJ	150	RF	17.61 [447]	23.54 [598]
G	2 x 3	1500	RF	300	RF	21.26 [540]	20.51 [521]
G	2 x 3	1500	RJ	300	RF	21.32 [541]	20.51 [521]
G	2 x 3	2500	RF	300	RF	21.26 [540]	20.51 [521]
G	2 x 3	2500	RJ	300	RF	21.32 [541]	20.51 [521]
G/H	1½ x 3	150	RF	150	RF	17.01 [432]	22.29 [566]
G/H	1½ x 3	300LW	RF	150	RF	17.39 [442]	22.29 [566]
G/H	1½ x 3	300	RF	150	RF	17.39 [442]	23.54 [598]
H	2 x 3	300	RF	150	RF	17.14 [435]	22.42 [569]
H	2 x 3	600	RF	150	RF	18.33 [466]	23.92 [607]
H	2 x 3	600	RJ	150	RF	18.52 [470]	23.92 [607]
H	2 x 3	600	RF	150	RF	17.46 [444]	22.42 [570]
H	2 x 3	600	RJ	150	RF	17.59 [447]	22.42 [570]
H	2 x 3	900	RF	150	RF	21.19 [538]	19.70 [500]
H	2 x 3	900	RJ	150	RF	21.25 [540]	19.70 [500]
H	2 x 3	1500	RF	300	RF	21.26 [540]	20.14 [511]
H	2 x 3	1500	RJ	300	RF	21.32 [541]	20.14 [511]

**Note:**

1. Calculated using 1/16" thick gaskets for RF connections and the spacing listed in Table 5 of ANSI B16.5 for RJ connections.

*continues on page 11*

**Tandem SSV with DSOPRVs**

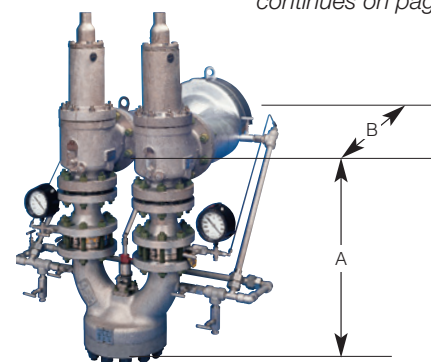

## Dimensions and Weights – Tandem Safety Selector Valve with Direct Spring Valves

### Tandem Safety Selector Valve with API 526 Direct Spring Operated PRVs

API Orifice	Inlet by Outlet Size	Inlet Flange		Outlet Flange		Tandem SSV Envelope Dimensions, inches [mm]	
		ANSI Pressure Class	Face Type	ANSI Pressure Class	Face Type	A	B
J	2 x 3	150	RF	150	RF	17.14 [435]	22.42 [569]
J	2 x 3	300LW	RF	150	RF	17.39 [442]	22.42 [569]
J	3 x 4	300	RF	150	RF	21.01 [534]	29.13 [740]
J	3 x 4	900	RF	150	RF	25.57 [649]	29.13 [740]
J	3 x 4	900	RJ	150	RF	25.79 [655]	29.13 [740]
J/K	3 x 4	600	RF	150	RF	21.39 [543]	29.13 [740]
J/K	3 x 4	600	RJ	150	RF	21.58 [548]	29.13 [740]
K	3 x 4	150	RF	150	RF	19.45 [494]	28.38 [721]
K	3 x 4	300	RF	150	RF	19.89 [505]	28.38 [721]
K	3 x 4	600	RF	150	RF	20.33 [516]	28.38 [721]
K	3 x 4	600	RJ	150	RF	20.45 [519]	28.38 [721]
L	3 x 4	150	RF	150	RF	19.45 [494]	28.50 [724]
L	3 x 4	300LW	RF	150	RF	19.89 [505]	28.50 [724]
L	4 x 6	300	RF	150	RF	23.75 [603]	34.45 [875]
L	4 x 6	600	RF	150	RF	24.69 [627]	35.32 [897]
L	4 x 6	600	RJ	150	RF	24.88 [632]	35.32 [897]
L	4 x 6	600	RF	150	RF	24.76 [629]	35.32 [897]
L	4 x 6	600	RJ	150	RF	24.95 [634]	35.32 [897]
L/M/N	4 x 6	900	RF	150	RF	29.71 [755]	36.07 [916]
L/M/N	4 x 6	900	RJ	150	RF	29.81 [757]	36.07 [916]
M	4 x 6	150	RF	150	RF	23.19 [589]	34.57 [878]
M	4 x 6	300	RF	150	RF	23.69 [602]	34.57 [878]
M	4 x 6	600	RF	150	RF	24.63 [626]	35.32 [897]
M	4 x 6	600	RJ	150	RF	24.82 [630]	35.32 [897]
N	4 x 6	150	RF	150	RF	23.94 [608]	35.57 [904]
N	4 x 6	300	RF	150	RF	24.44 [621]	35.57 [904]
N	4 x 6	600	RF	150	RF	25.38 [645]	36.07 [916]
N	4 x 6	600	RJ	150	RF	25.57 [649]	36.07 [916]
P	4 x 6	150	RF	150	RF	23.32 [592]	36.32 [923]
P	4 x 6	300	RF	150	RF	23.82 [605]	36.32 [923]
P	4 x 6	300	RF	150	RF	25.57 [649]	37.32 [948]
P	4 x 6	600	RF	150	RF	26.51 [673]	37.32 [948]
P	4 x 6	600	RJ	150	RF	26.70 [678]	37.32 [948]
P	4 x 6	900	RF	150	RF	30.84 [783]	37.32 [948]
P	4 x 6	900	RJ	150	RF	30.94 [786]	37.32 [948]
Q	6 x 8	600	RF	150	RF	31.86 [809]	42.53[1080]
Q	6 x 8	600	RJ	150	RF	32.06 [814]	42.53[1080]
Q/R	6 x 8	150	RF	150	RF	29.67 [754]	42.53 [1080]
Q/R	6 x 8	300	RF	150	RF	30.67 [779]	42.53[1080]
T/T2 <sup>2</sup>	8 x 10	150	RF	150	RF	35.63 [905]	34.31 [871]

**Notes:**

1. Calculated using 1/16" thick gaskets for RF connections and the spacing listed in Table 5 of ANSI B16.5 for RJ connections.
2. **Dimensions using Crosby JOS-E/JBS-E/JLT-E pressure relief valves.** A = 47.30 [1201.42] B = 56.69 [1439.93] Expanders are required on both the inlet and outlet Safety Selector Valves. Contact your sales representative for details.

# Anderson Greenwood Safety Selector Valve

Dual Pressure Relief Device System

## Ordering Information

SVR

08

12

F

-

C

S

T

O

### Connection Size

04 - 1"	16 - 4"
06 - 1 1/2"	24 - 6"
08 - 2"	32 - 8"
10 - 2 1/2"	40 - 10"
12 - 3"	

### Pressure Class

05 - ANSI 150	14 - ANSI 900
10 - ANSI 300	16 - ANSI 1500
12 - ANSI 600	18 - ANSI 2500

### Connection Type

- F - Raised Face Flange (1" to 8")
- J - Ring Joint Flange (1" to 8")
- T - Threaded (1" to 3")
- X - Special

### Body Material

A - Aluminum	M - Monel®
C - CS	N - Inconel®
D - Duplex	S - SS
H - Hastelloy®	X - Other (note type on order - contact your sales representative)

### Trim Material

S - SS	D - Duplex
H - Hastelloy®	N - Inconel®
M - Monel®	X - Other (contact your sales representative)

### Soft Goods

- T - Teflon® 400°F [200°C]
- G - GRAFOIL® 800°F [426°C]
- P - PEEK (with GRAFOIL® packing) 600°F [315°C]
- X - Special (contact your sales representative)

### Options

- O - Standard (Inlet Valve)
- T - Tandem (Outlet Valve)
- B - Built per ASME Boiler and Pressure Vessel Code Section I, Code Case 2254 (see page 2)
- X - Special - note on order required options

Tyco Flow Control (TFC) provides the information herein in good faith but makes no representation as to its comprehensiveness or accuracy. This data sheet is intended only as a guide to TFC products and services. Individuals using this data sheet must exercise their independent judgment in evaluating product selection and determining product appropriateness for their particular purpose and system requirements. TFC MAKES NO REPRESENTATIONS OR WARRANTIES, EITHER EXPRESS OR IMPLIED, INCLUDING WITHOUT LIMITATION ANY WARRANTIES OF MERCHANTABILITY OR FITNESS FOR A PARTICULAR PURPOSE WITH RESPECT TO THE INFORMATION SET FORTH HEREIN OR THE PRODUCT(S) TO WHICH THE INFORMATION REFERS. ACCORDINGLY, TFC WILL NOT BE RESPONSIBLE FOR DAMAGES (OF ANY KIND OR NATURE, INCLUDING INCIDENTAL, DIRECT, INDIRECT, OR CONSEQUENTIAL DAMAGES) RESULTING FROM THE USE OF OR RELIANCE UPON THIS INFORMATION. All Patents and Patents Pending in the U.S. and foreign countries are property of their respective owners. Tyco reserves the right to change product designs and specifications without notice. All registered trademarks are the property of their respective owners. Printed in the USA.