

ANDERSON GREENWOOD

Premium performance, direct spring operated pressure relief valves use special internals and soft seats to provide optimum, accurate performance.

Features and Benefits

- Soft seat design as standard. Helps provide repeatable leak-tight performance before and after each relief cycle.
- Leak-tight performance near set pressure. Allows higher operating pressure, resulting in increased process throughput and system optimization.
- Replaceable soft seat and seals. Easy seat and seal replacement, compared to refurbishment (no expensive, time consuming lapping of metal components) results in lower long-term maintenance costs.
- External adjustable blowdown (Types 81/83/86). Allows for precise adjustment of reseal pressure without affecting set pressure adjustment. Adjustment does not require access to valve internal trim, blowdown can be adjusted with valve in service, helping eliminate the need for costly removal and/or system shut down.
- Full lift at set pressure (Types 81/83/86). No overpressure required for full lift. Minimizes possibility of freeze-up in applications involving a cryogenic or refrigerant and allows for D.O.T. applications to be set higher than Maximum Allowable Operating Pressure (MAOP).
- Balanced spindle design (Type 81P). Balanced against the effects of back pressure without the use of a bellows, reducing cost of both the initial valve purchase and associated long-term maintenance.
- Meets ASME Section VIII requirements. Provides the user third-party verification of valve capacity and performance.

Anderson Greenwood is either a trademark or registered trademark of Tyco International Services AG or its affiliates in the United States and/or other countries. All other brand names, product names, or trademarks belong to their respective holders.



Contents

Features and Benefits	1
Overview	2-3
How to Size a Valve	4
Sizing Formulas	5-9
Physical Properties	10-14
Conversion Tables	15-17
How to Finalize Your Selection	18
Pressure and Temperature Ratings	19-22
Dimensions and Weights	23-34
Materials of Construction	35-40
Additional Information	41
Model Number Selection Tables	42-44
Accessories and Options	45
Operation – Types 81, 83 and 86	46-47
Operation – Types 81P, 61, and 63B	48-49
Capacity Tables	50-55
Seat Tightness Performance	56

Product Overview

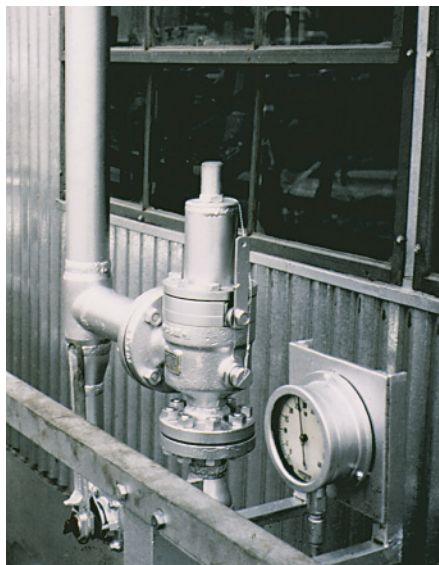

Our premium performance direct spring operated pressure relief valves use special internals and soft seats to provide optimum, accurate performance. Specific valve types are available for gas, vapor, liquid, gas or liquid thermal relief, and steam applications.

Types 81, 83, 86 Safety Valves

The Type 81 direct spring operated safety valve, with an inert plastic seat, is suitable for a wide range of products, pressures, and temperatures involving gas, vapor, and liquid or gas thermal relief applications. It allows maintained tightness close to set pressure, opens fully at set pressure, and provides a safe, external adjustment for short blowdown. The Type 81 valve is best suited for cryogenic, high set pressure, and chemically active applications.

The Type 83 direct spring operated safety valve, with an elastomer seat, is ideal for gas processes that operate close to set pressure, for controlling valuable or polluting gas products that should not be lost to the atmosphere, and for liquid or gas thermal relief applications. It allows maintained tightness close to set pressure, opens fully at set pressure, and provides a safe, external adjustment for short blowdown. The Type 83 is best suited for hard-to-hold gases and vapors, and general gas or vapor service.

The Type 86 direct spring operated safety valve, with a thermoplastic seat, is designed for steam service. The performance of the valve allows processes to operate close to set pressure without eroding the seat causing leakage and high maintenance.

The huddling chamber of all three of these valve types has been optimized to provide full opening at set pressure. In addition, there is a unique, independent control of the blowdown via an external adjustment screw. The huddling chamber is powerful enough to generate a lifting force to fully lift the disk (spindle) against the spring force, without any overpressure.

Closing is assisted by the development of a controlled back pressure in the spring chamber. This pressure helps the spring close the valve after actuating. This unique design uses this controlled back pressure in the spring chamber to precisely control the magnitude of blowdown to a reasonable level.

Type 81P Relief Valve

The Type 81P is a soft-seated, balanced, direct spring operated pressure relief valve intended for liquid applications. This valve is rated at full capacity at 10 percent overpressure and meets the latest requirements of Section VIII, Division 1 of the ASME Unfired Pressure Vessel Code.

The Type 81P is very similar to the Type 81, but the internal nozzle, guide, and spindle assembly are made especially for the unique demands of liquid service. The spindle assembly uses three replaceable sealing members: a specially engineered plastic seat and two elastomer seals. The two seals help balance against back pressure and stabilize against destructive chatter. The nozzle fits closely with the guide, providing perfect alignment for the spindle. Multiple discharge holes in the guide provide free discharge of the relieving flow to the valve outlet.

The spring chamber is isolated by the guide seal and the back pressure (balancing) seal on the stem of the spindle, and is vented to the atmosphere. Thus, the valve remains fully balanced and operational without the need for an expensive bellows.

The stem of the spindle has a sealing diameter equal to the seat-to-nozzle contact diameter. This provides complete balancing against the effects of superimposed back pressure.

The stabilizing ring consists of an O-ring, with a pressure passage that allows system pressure to pass through the seat retainer screw to force the O-ring against the guide. This provides a variable resistance to spindle movement, proportional to system pressure. The unpredictable chattering behavior of many liquid safety relief valves is completely eliminated by this pressure-energized stabilizing ring. The possibility of destructive shock waves, which could damage piping and associated pressure-containing members, is greatly reduced.

Types 61 and 63B Safety Valves

The Types 61 and 63B are direct spring operated safety valves suitable for low and medium set pressure gas, vapor, and liquid or gas thermal relief applications. Brass construction offers an economical valve for carbon dioxide, natural gas, and general gas or vapor services. The Type 61 is also suitable for cryogenic and chemically active applications.

Overview

Three steps make it easy to select, size and order the valve. The flow of the three steps is described below.

Step 1, Preliminary valve selection: helps you determine the type of valve that best suits your application.

Step 2, Sizing: provides the information you need to choose the correct valve orifice area.

Step 3, Ordering: explains how to finalize valve selection and order the specific model number, after you have chosen the appropriate valve type and size.

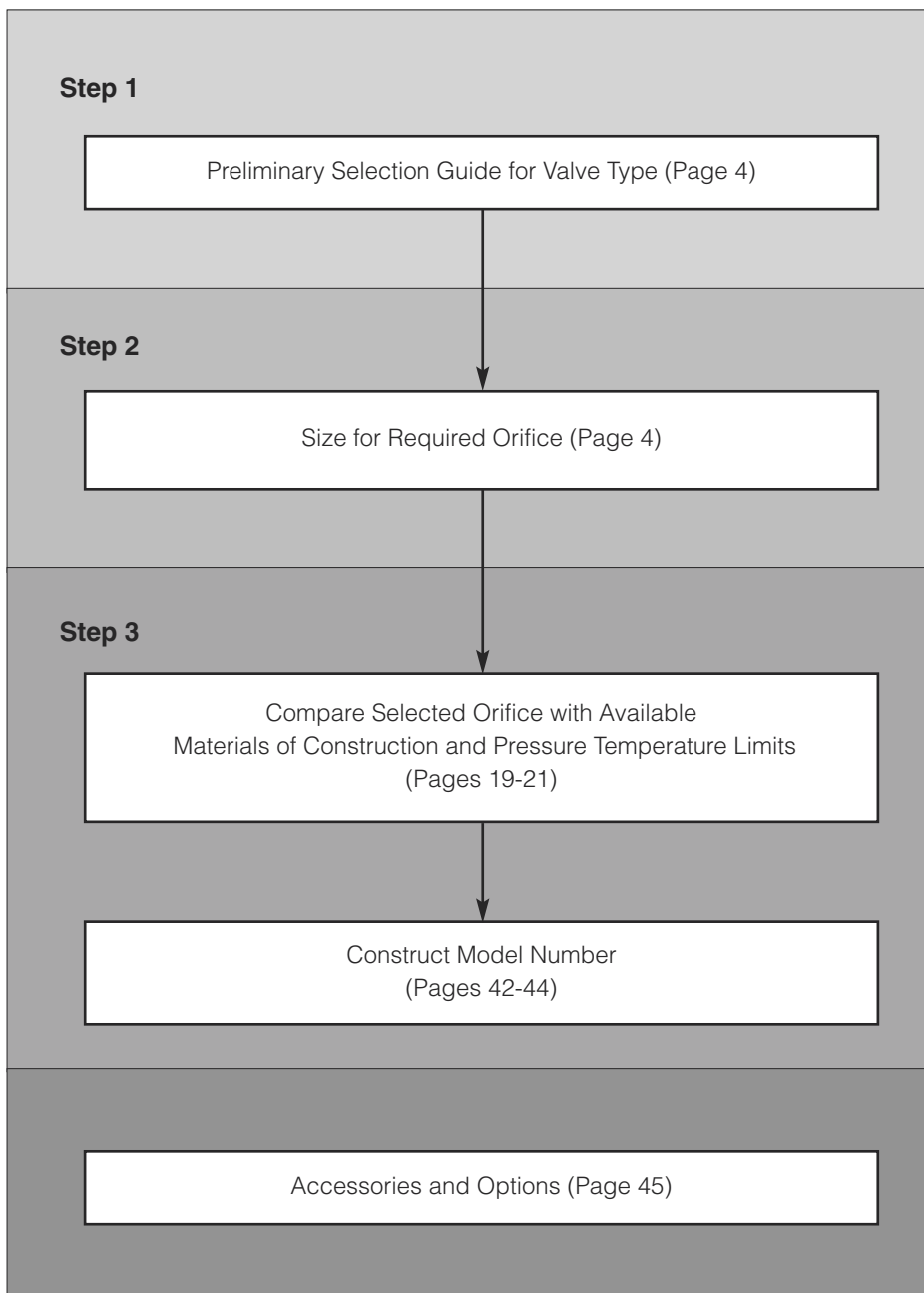

Preliminary Selection Guide

Valve Type	Applications				Seat Type	Body Material			Set Pressure		Relieving Temperature		Balanced for Back Pressure
	Gas/Vapor	Liquid	Gas/Liquid Thermal Relief	Steam		Brass	CS	SS	psig	[barg]	°F	[°C]	
81	X		X		Plastic	X	X	X	50 to 10,000	[3.45 to 689.5]	-423°F to 500°F	[-253°C to 260°C]	N
81P		X	X		Plastic	X	X	X	50 to 6,000	[3.45 to 413.7]	-65°F to 400°F	[-54°C to 205°C]	Y
83	X		X		O-ring	X	X	X	20 to 2,000	[1.40 to 137.9]	-65°F to 550°F	[-54°C to 288°C]	N
86				X	Plastic	X	X	X	50 to 720	[3.45 to 49.6]	-423°F to 515°F	[-253°C to 268°C]	N
61	X		X		Plastic	X			30 to 500	[2.07 to 34.5]	-320°F to 400°F	[-196°C to 205°C]	N
63B	X		X		O-ring	X			37 to 531	[2.55 to 36.6]	-65°F to 400°F	[-54°C to 205°C]	N

Note

1. Minimum and maximum set pressures may not be available in all orifice sizes (see pages 19-22).

Sizing – How to Size a Valve

Pressure relief valves are selected on the basis of their ability to meet an expected relieving condition and flowing a sufficient amount of fluid to prevent excessive pressure increase. This means that the size of the valve orifices must be calculated taking the required flow, lading fluid properties, and other factors into consideration.

To select the minimum required orifice area that will flow the required capacity of the system you wish to protect, please refer to the following information, which appears in this section:

1. Sizing formulas.
2. Physical properties of the fluid to be relieved.
3. Capacities of different orifice areas at different pressures.
4. Conversion tables to aid calculations.

Once you have determined the required orifice area for your service conditions, refer to pages 18-44, for selecting and ordering a specific valve model number.

Orifice Areas and Nozzle Coefficient

The orifice areas and nozzle coefficients for all Series 80 valves are tabulated in the table below.

These values are derived from the values certified by the National Board of Boiler and Pressure Vessel Inspectors, in accordance with Section VIII, Division 1 of the ASME Pressure Vessel Code.

Verification of Sizing

Orifice area calculations are made and/or verified whenever sufficient data is provided. If no data is furnished, the size selection responsibility will remain totally with the purchaser.

Nozzle Coefficient and Available Orifice Sizes, in² [cm²]

Valve Type	K	0.049 [0.316] (-4)	0.077 [0.497] (-5)	0.110 [0.710] (-6)	0.150 [0.968] (-7)	0.196 [1.265] (-8 or E)	0.307 [1.981] (F)	0.503 [3.245] (G)	0.785 [5.065] (H)	1.287 [8.303] (J)
81	0.816	X		X		X	X	X	X	X
81P	0.720	X				X		X		X
83	0.816	X		X		X	X	X	X	X
86	0.816	X				X		X		X
61	0.878			X						
63B	0.835		X							
63B	0.861				X					

Sizing – English Sizing Formulas

Vapors or Gases (capacity in SCFM)¹

$$A = \frac{V \sqrt{MTZ}}{6.32 CKP_1}$$

Vapors or Gases (capacity in lb/hr)¹

$$A = \frac{W \sqrt{TZ}}{CKP_1 \sqrt{M}}$$

Steam (capacity in lb/hr)¹

$$A = \frac{W}{51.5 K P_1 K_S}$$

Liquids (capacity in gpm)

$$A = \frac{V_L \sqrt{G}}{38 K K_P K_W K_V \sqrt{P_A - P_B}}$$

English Sizing Formulas

V = Required capacity, SCFM

W = Required capacity, lb/hr

V_L = Required capacity, gpm

G = Specific gravity of liquid at flowing temperature referred to water = 1.00 at 70°F (see Physical Properties on pages 12-14)

M = Molecular weight of vapor or gas (M = 29 x G, see Physical Properties on pages 10-11)

T = Relief temperature, °R (°R = °F + 460)

Z = Compressibility factor (if unknown, assume Z = 1.0)

k = Specific heat ratio $k = \frac{C_p}{C_v}$

C = Gas constant based on k (if unknown, assume C = 315; see Physical Properties on pages 10-11; also see page 8)

K = Nozzle coefficient for 90 percent of actual capacity, derived from National Board Certified Testing (see page 4)

P₁ = Inlet flowing pressure, psia = Set pressure - inlet pressure loss + allowable overpressure + 14.7P_A = Inlet flowing pressure, psig = Set pressure - inlet pressure loss + allowable overpressureP_B = Back pressure - psigK_p = Overpressure correction factor, 1.0K_w = Back pressure correction factor (see page 7)K_v = Viscosity correction factor (see page 7)K_s = Superheat correction factor (for saturated steam, K_s = 1.0, refer to Table on page 9)

Note

- As is accepted industry practice, built-up back pressure for conventional (unbalanced) gas or steam valves should not exceed 10 percent.

Sizing – Metric Sizing Formulas

Vapors or Gases (capacity in Nm³/hr)¹

$$A = \frac{V \sqrt{MTZ}}{17.02 CKP_1}$$

Vapors or Gases (capacity in kg/hr)¹

$$A = \frac{1.316 W \sqrt{TZ}}{CKP_1 \sqrt{M}}$$

Steam (capacity in kg/hr)¹

$$A = \frac{W}{52.5 K P_1 K_S}$$

Liquids (capacity in M³/hr)

$$A = \frac{0.19631 V_L \sqrt{G}}{K K_P K_W K_V \sqrt{P_A - P_B}}$$

Metric Sizing Formulas

A = Calculated orifice area, cm²

V = Required capacity, Nm³/hr

W = Required capacity, kg/hr

V_L = Required capacity, M³/hr

G = Specific gravity (Relative Density) of liquid at flowing temperature referred to water = 1.00 at 20°C (see Physical Properties on pages 12-14)

M = Molecular weight of vapor or gas (M = 29 x G, see Physical Properties on pages 10-11)

T = Relief temperature, °K (°K = °C + 273)

Z = Compressibility factor (if unknown, assume Z = 1.0)

k = Specific heat ratio $k = \frac{C_p}{C_v}$

C = Gas constant based on k (if unknown, assume C = 315; see Physical Properties on pages 10-14; also see page 8)

K = Nozzle coefficient for 90 percent of actual capacity, derived from National Board Certified Testing (see page 4)

P₁ = Inlet flowing pressure, bara = Set pressure - inlet pressure loss + allowable overpressure + 1.013 barg

P_A = Inlet flowing pressure, psig = Set pressure - inlet pressure loss + allowable overpressure

P_B = Back pressure, barg

K_p = Overpressure correction factor, 1.0

K_w = Back pressure correction factor (see page 7)

K_v = Viscosity correction factor (see page 7)

K_s = Superheat correction factor (for saturated steam, K_s = 1.0, refer to Table on page 9)

Note

- As is accepted industry practice, built-up back pressure for conventional (unbalanced) gas or steam valves should not exceed 10 percent.

Sizing – Determining K_V and K_W

English Units

$$R = \frac{V_L (2,800 G)}{\mu \sqrt{A}}$$

or

$$R = \frac{12,700 V_L}{U \sqrt{A}}$$

Metric Units

$$R = \frac{31,313 V_L G}{\mu \sqrt{A}}$$

Determining K_V

V_L = Flow rate at the flowing temperature, in U.S. gpm [m³/hr]

G = Specific gravity of liquid at flowing temperature referred to water = 1.00 at 70°F [21°C]

μ = Absolute viscosity at the flowing temperature, in centipoise

A = Effective discharge area, in square inches [cm²] (from manufacturer's standard orifice areas)

U = Viscosity at the flowing temperature, in Saybolt Universal seconds

After the value of R is determined, the factor K_V is obtained from the graph. Factor K_V is applied to correct the "preliminary required discharge area." If the corrected area exceeds the "chosen standard orifice area," the calculations should be repeated using the next larger standard orifice size.

Determining K_W

See graph at right.

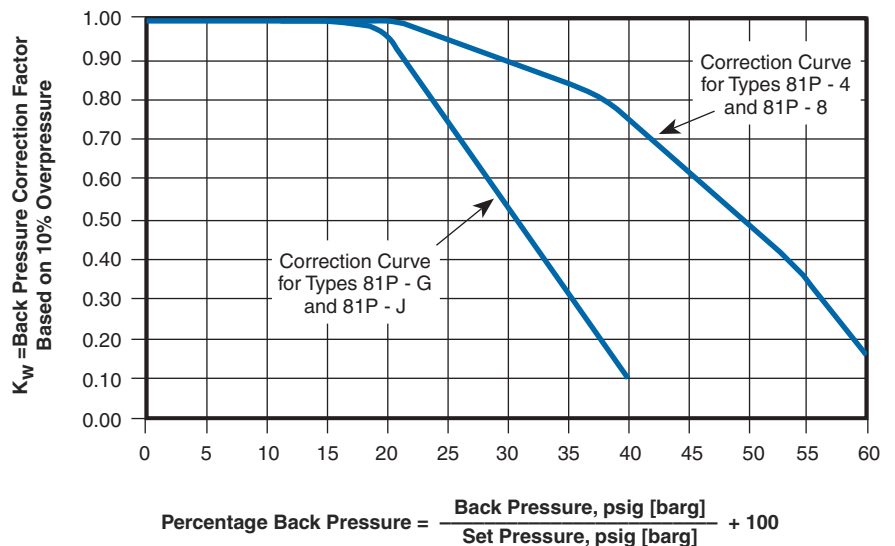
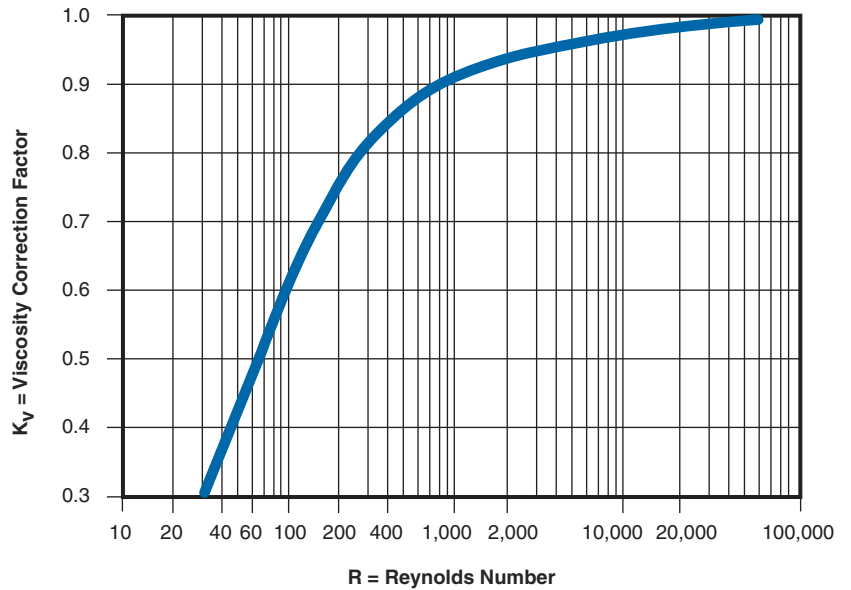

$$\text{Percentage Back Pressure} = \frac{\text{Back Pressure, psig [barg]}}{\text{Set Pressure, psig [barg]}} + 100$$

Sizing

Determining C, based on k – Gas Constant, C

k	C	k	C
1.00	315	1.52	366
1.02	318	1.54	368
1.04	320	1.56	369
1.06	322	1.58	371
1.08	324	1.60	372
1.10	327	1.62	374
1.12	329	1.64	376
1.14	331	1.66	377
1.16	333	1.68	379
1.18	335	1.70	380
1.20	337	1.72	382
1.22	339	1.74	383
1.24	341	1.76	384
1.26	343	1.78	386
1.28	345	1.80	387
1.30	347	1.82	388
1.32	349	1.84	390
1.34	351	1.86	391
1.36	352	1.88	392
1.38	354	1.90	394
1.40	356	1.92	395
1.42	358	1.94	397
1.44	359	1.96	398
1.46	361	1.98	399
1.48	363	2.00	400
1.50	364	2.02	401

Sizing

Steam Super Heat Correction Factor, K_S																			
Set Pressure psig [barg]		Saturated Steam Temp °F [°C]		Total Steam Temperature in, °F [°C]															
				300 [149]	320 [160]	340 [171]	360 [182]	380 [193]	400 [205]	420 [216]	440 [227]	460 [238]	480 [249]	500 [260]	520 [271]	540 [282]	560 [293]		
50	3.5	298	[148]	1.00	1.00	1.00	0.99	0.99	0.98	0.97	0.96	0.95	0.94	0.93	0.92	0.91	0.90		
60	4.1	308	[153]		1.00	1.00	0.99	0.99	0.98	0.97	0.96	0.95	0.94	0.93	0.92	0.91	0.90		
80	5.5	324	[162]			1.00	1.00	0.99	0.99	0.98	0.97	0.96	0.94	0.93	0.92	0.91	0.90		
100	6.9	338	[170]				1.00	1.00	0.99	0.98	0.97	0.96	0.95	0.94	0.93	0.92	0.91		
120	8.3	350	[177]				1.00	1.00	0.99	0.98	0.97	0.96	0.95	0.94	0.93	0.92	0.91		
140	9.7	361	[183]					1.00	1.00	0.99	0.98	0.96	0.95	0.94	0.93	0.92	0.91		
160	11.0	371	[188]					1.00	1.00	0.99	0.98	0.97	0.95	0.94	0.93	0.92	0.91		
180	12.4	380	[193]						1.00	0.99	0.98	0.97	0.96	0.95	0.93	0.92	0.91		
200	13.8	388	[198]						1.00	0.99	0.99	0.97	0.96	0.95	0.93	0.92	0.91		
220	15.2	395	[202]						1.00	1.00	0.99	0.98	0.96	0.95	0.94	0.93	0.92		
240	16.6	403	[206]							1.00	0.99	0.98	0.97	0.95	0.94	0.93	0.92		
260	17.9	409	[210]							1.00	0.99	0.98	0.97	0.96	0.94	0.93	0.92		
280	19.3	416	[213]							1.00	1.00	0.99	0.97	0.96	0.95	0.93	0.92		
300	20.7	422	[217]								1.00	0.99	0.98	0.96	0.95	0.93	0.92		
350	24.1	436	[225]								1.00	1.00	0.99	0.97	0.96	0.94	0.93		
400	27.6	448	[231]									1.00	0.99	0.98	0.96	0.95	0.93		
450	31.0	460	[238]										1.00	0.99	0.97	0.96	0.94		
500	34.5	470	[243]										1.00	0.99	0.98	0.96	0.94		
550	37.9	480	[249]											1.00	0.99	0.97	0.95		
600	41.4	489	[254]											1.00	0.99	0.98	0.96		
650	44.8	497	[258]												1.00	0.99	0.97		
700	48.3	506	[263]													1.00	0.99	0.97	
750	51.7	513	[267]														1.00	1.00	0.98

Sizing

Physical Properties

Gas or Vapor	M Molecular Weight	k Specific Heat Ratio	C Gas Constant
Acetone	58.08	1.12	329
Acetylene (Ethyne)	26.04	1.26	343
Air	28.97	1.40	356
Ammonia, Anhydrous	17.03	1.31	348
Argon	39.95	1.67	378
Benzene (Benzol or Benzole)	78.11	1.12	329
Boron Trifluoride	67.82	1.20	337
Butadiene-1, 3 (Divinyl)	54.09	1.12	329
Butane-n (Normal Butane)	58.12	1.09	326
Butylene (1-Butene)	56.11	1.11	328
Carbon Dioxide	44.01	1.29	346
Carbon Disulfide (C. Bisulfide)	76.13	1.21	33
Carbon Monoxide	28.01	1.40	356
Carbon Tetrachloride	153.82	1.11	328
Chlorine	70.91	1.36	353
Chloromethane (Methyl Chloride)	50.49	1.28	345
Cyclohexane	84.16	1.09	326
Cyclopropane (Trimethylene)	42.08	1.11	328
Decane-n	142.29	1.04	320
Diethylene Glycol (DEG)	106.17	1.07	323
Dimethyl Ether (Methyl Ether)	46.07	1.11	328
Dowtherm A	165.00	1.05	321
Dowtherm E	147.00	1.00	315
Ethane	30.07	1.19	336
Ethyl Alcohol (Ethanol)	46.07	1.13	330
Ethylene (Ethene)	28.05	1.24	341
Ethylene Glycol	62.07	1.09	326
Ethylene Oxide	44.05	1.21	338
Fluorocarbons:			
12, Dichlorodifluoromethane	120.93	1.14	331
13, Chlorotrifluoromethane	104.47	1.17	334
13B1, Bromotrifluoromethane	148.93	1.14	331
22, Chlorodifluoromethane	86.48	1.18	335
115, Chloropentafluoroethane	154.48	1.08	324
Glycerine (Glycerin or Glycerol)	92.10	1.06	322
Helium	4.00	1.67	378
Heptane	100.21	1.05	321

Sizing

Physical Properties

Gas or Vapor	M Molecular Weight	k Specific Heat Ratio	C Gas Constant
Hexane	86.18	1.06	322
Hydrogen	2.02	1.41	357
Hydrogen Chloride, Anhydrous	36.46	1.41	357
Hydrogen Sulfide	34.08	1.32	349
Isobutane (2-Methylpropane)	58.12	1.10	327
Isoprene (2-Methyl-1, 3 Butadiene)	68.12	1.09	326
Isopropyl Alcohol (Isopropanol)	60.10	1.09	326
Krypton	83.80	1.71	380
Methane	16.04	1.31	348
Methyl Alcohol (Methanol)	32.04	1.20	337
Methylamines, Anhydrous			
Monomethylamine (Methylamine)	31.06	1.02	317
Dimethylamine	45.08	1.15	332
Trimethylamine	59.11	1.18	335
Methyl Mercaptan (Methanethiol)	48.11	1.20	337
Napthalene (Napthaline)	128.17	1.07	323
Natural Gas (specific gravity = 0.60)	17.40	1.27	344
Neon	20.18	1.64	375
Nitrogen	28.01	1.40	356
Nitrous Oxide	44.01	1.30	347
Octane	114.23	1.05	321
Oxygen	32.00	1.40	356
Pentane	72.15	1.07	323
Propadiene (Allene)	40.07	1.69	379
Propane	44.10	1.13	330
Propylene (Propene)	42.08	1.15	332
Propylene Oxide	58.08	1.13	330
Styrene	104.15	1.07	323
Sulfur Dioxide	64.06	1.28	345
Sulfur Hexafluoride	146.05	1.09	326
Steam	18.02	1.31	348
Toluene (Toluol or Methylbenzene)	92.14	1.09	326
Triethylene Glycol (TEG)	150.18	1.04	320
Vinyl Chloride Monomer (VCM)	62.50	1.19	336
Xenon	131.30	1.65	376
Xylene (p-Xylene)	106.17	1.07	323

Sizing

Physical Properties

Liquid	G Specific Gravity Water = 1	°F	[°C]
Acetaldehyde	0.779	68	20
Acetic Acid	1.051	68	20
Acetone	0.792	68	20
Ammonia, Anhydrous	0.666	68	20
Automotive Crankcase and Gear Oils:			
SAE-5W Through SAE 150	0.88-0.94	60	15.6
Beer	1.01	60	15.6
Benzene (Benzol)	0.880	68	20
Boron Trifluoride	1.57	-148	-100
Butadiene - 1, 3	0.622	68	20
Butane-n (Normal Butane)	0.579	68	20
Butylene (1-Butene)	0.600	68	20
Carbon Dioxide	1.03	-4	-20
Carbon Disulfide (C. Bisulfide)	1.27	68	20
Carbon Tetrachloride	1.60	68	20
Chlorine	1.42	68	20
Chloromethane (Methyl Chloride)	0.921	68	20
Crude Oils:			
32.6 Deg API	0.862	60	15.6
35.6 Deg API	0.847	60	15.6
40 Deg API	0.825	60	15.6
48 Deg API	0.79	60	15.6
Cyclohexane	0.780	68	20
Cyclopropane (Trimethylene)	0.621	68	20
Decane-n	0.731	68	20
Diesel Fuel Oils	0.82-0.95	60	15.6
Diethylene Glycol (DEG)	1.12	68	20
Dimethyl Ether (Methyl Ether)	0.663	68	20
Dowtherm A	0.998	68	20
Dowtherm E	1.087	68	20
Ethane	0.336	68	20
Ethyl Alcohol (Ethanol)	0.79	68	20
Ethylene (Ethene)	0.569	-155	-104
Ethylene Glycol	1.115	68	20
Ethylene Oxide	0.901	68	20

Sizing

Physical Properties

Liquid	G Specific Gravity Water = 1	°F	[°C]
Fluorocarbons:			
R12, Dichlorodifluoromethane	1.34	68	20
R13, Chlorotrifluoromethane	0.916	68	20
R13B1, Bromotrifluoromethane	1.58	68	20
R22, Chlorodifluoromethane	1.21	68	20
R115, Chloropentafluoromethane	1.31	68	20
Fuel Oils, Nos. 1, 2, 3, 5 and 6	0.82-0.95	60	15.6
Gasolines	0.68-0.74	60	15.6
Glycerine (Glycerin or Glycerol)	1.26	68	20
Heptane	0.685	68	20
Hexane	0.660	68	20
Hydrochloric Acid	1.64	60	15.6
Hydrogen Sulfide	0.78	68	20
Isobutane (2-Methylpropane)	0.558	68	20
Isoprene (2-Methyl - 1, 3-Butadiene)	0.682	68	20
Isopropyl Alcohol (Isopropanol)	0.786	68	20
Jet Fuel (average)	0.82	60	15.6
Kerosene	0.78-0.82	60	15.6
Methyl Alcohol (Methanol)	0.792	68	20
Methylamines, Anhydrous:			
Monomethylamine (Methylamine)	0.663	68	20
Dimethylamine	0.656	68	20
Trimethylamine	0.634	68	20
Methyl Mercaptan (Methanethiol)	0.870	68	20
Nitric Acid	1.50	60	15.6
Nitrous Oxide	1.23	-127	-88.5
Octane	0.703	68	20
Pentane	0.627	68	20
Propadiene (Allene)	0.659	-30	-34.4
Propane	0.501	68	20
Propylene (Propene)	0.514	68	20
Propylene Oxide	0.830	68	20
Styrene	0.908	68	20
Sulfur Dioxide	1.43	68	20

Sizing

Physical Properties

Liquid	G Specific Gravity Water = 1	°F	[°C]
Sulfur Hexafluoride	1.37	68	20
Sulfuric Acid:			
95 – 100%	1.839	68	20
60%	1.50	68	20
20%	1.14	68	20
Toluene (Toluol or Methylbenzene)	0.868	68	20
Triethylene Glycol (TEG)	1.126	68	20
Vinyl Chloride Monomer (VCM)	0.985	-4	-20
Water, fresh	1.00	68	20
Water, sea	1.03	68	20
Xylene (p-Xylene)	0.862	68	20

Sizing – Gas Flow Conversions

Notes

1. M = Molecular weight of vapor or gas.
2. Volumetric flow (per time unit of hour or minute as shown) in standard cubic feet per minute at 14.7 psia [1.013 bara], 60°F [16°C].
3. Weight flow in pounds per hour.
4. Weight flow in kilograms per hour.
5. Volumetric flow (per time unit of hour or minute as shown) at 1.013 bara 32°F [0°C]. This represents the commercial standard, known as the Normal Temperature and Pressure (NTP).

Conversions from one volumetric flow rate to another or to weight flow (and vice versa) may only be done when the volumetric flow is expressed in the standard conditions shown above. If flows are expressed at temperature or pressure bases that differ from those listed above, they must first be converted to the standard base.

Gas Flow Conversions

Given	To find desired value, multiply "Given" value by factor below					
	SCFM	SCFH	lb/hr	[kg/hr]	[Nm ³ /hr]	[Nm ³ /min]
scfm ²	—	60	$\frac{M}{6.32}$	$\frac{M}{13.93}$	1.608	0.0268
scfh ²	0.01677	—	$\frac{M}{379.2}$	$\frac{M}{836.1}$	0.0268	0.000447
lb/hr ³ or #/hr ³	$\frac{6.32}{M}$	$\frac{379.2}{M}$	—	0.4536	$\frac{10.17}{M}$	$\frac{0.1695}{M}$
kg/hr ⁴	$\frac{13.93}{M}$	$\frac{836.1}{M}$	2.205	—	$\frac{22.40}{M}$	$\frac{0.3733}{M}$
Nm ³ /hr ⁵	0.6216	37.30	$\frac{M}{10.17}$	$\frac{M}{22.40}$	—	0.01667
Nm ³ /min ⁵	37.30	2238	5.901 M	2.676 M	60	—

If flow is expressed in actual volume, such as cfm (cubic feet per minute) or acfm (actual cfm) as is often done for compressors, where the flow is described as displacement or swept volume, the flow may be converted to scfm as follows (or from flow expressed in m³/hr to Nm³/hr).

Inch-Pound Units

$$\text{SCFM} = \left(\begin{array}{c} \text{cfm} \\ \text{or} \\ \text{acfm} \end{array} \right) \times \frac{14.7 + p}{14.7} \times \frac{520}{460 + t}$$

Where:

p = gauge pressure of gas or vapor in psig

t = temperature of gas or vapor in °F

Metric Units

$$\text{Nm}^3/\text{hr} = \text{n}^3/\text{hr} \times \frac{1.013 + p}{1.013} \times \frac{273}{273 + t}$$

Where:

p = gauge pressure of gas or vapor in barg

t = temperature of gas or vapor in °C

Sizing – Pressure Conversion

Pressure Conversion

Given	To find desired value, multiply "Given" value by factor below			
	kPa	psig	kg/cm ²	barg
kPa (kilopascal)	—	0.1450	0.0102	0.0100
psig (pounds/in ²)	6.895	—	0.0703	0.06895
kg/cm ² (kilograms/cm ²)	98.07	14.22	—	0.9807
barg	100.00	14.50	1.020	—

Area Conversion

Given	To find desired value, multiply "Given" value by factor below			
	in ²	ft ²	mm ²	cm ²
in ²	—	0.006944	645.16	6.4516
cm ²	0.155	1.076 x 10 ⁻³	100	—
ft ²	144	—	92900	929
mm ²	0.00155	1.076 x 10 ⁻⁵	—	0.01

Note

1. Normal Temperature and Pressure (NTP) Conditions are, at sea level, equal to 1.013 bara or 1.033 kg/cm² (kilograms force per square centimeter absolute) at a base temperature of 32°F [0°C]. This differs slightly from Metric Standard Conditions (MSC), which uses 1.013 bara 60°F [15°C] for the base temperature.

Sizing – Conversion Factors

Notes

1. Kinematic viscosity x specific gravity = absolute viscosity.
2. Centistokes x specific gravity = centipoise.
3. Saybolt Second Universal (SSU) x 0.216 x specific gravity = centipoise.

Absolute Viscosity

Given	To find desired value, multiply "Given" value by factor below			
	poise	Centipoise	$\frac{\text{gm}}{\text{cm-sec}}$	$\frac{\text{lb}}{\text{ft-sec}}$
poise	—	100	1	0.0672
centipoise	0.01	—	0.01	0.000672
$\frac{\text{gm}}{\text{cm-sec}}$	1	100	—	0.0672
$\frac{\text{lb}}{\text{ft-sec}}$	14.88	1488	14.88	—

Kinematic Viscosity

Given	To find desired value, multiply "Given" value by factor below			
	stoke	Centistoke	$\frac{\text{cm}^2}{\text{sec}}$	$\frac{\text{ft}^2}{\text{sec}}$
stoke	—	100	1	0.001076
centistoke	0.01	—	0.01	1.076×10^{-5}
$\frac{\text{cm}^2}{\text{sec}}$	1	100	—	0.001076
$\frac{\text{ft}^2}{\text{sec}}$	929.0	92900	929.0	—

Note

1. G = Specific gravity of liquid at its relieving temperature compared to that of water at 68°F [20°C], where $G_{\text{water}} = 1.00$.

Liquid Flow Conversions

Given	To find desired value, multiply "Given" value by factor below				
	l/hr	gpm - US	gpm - Imp	barrels/day	m ³ /hr
l/hr (litres/hour)	—	0.00440	0.003666	0.1510	0.0010
gpm (US gallons per minute)	227.1	—	0.8327	34.29	0.2271
gpm (Imperial gallons per minute)	272.8	1.201	—	41.18	0.2728
barrels/day (petroleum - 42 US gallons)	6.624	0.02917	0.02429	—	0.006624
m ³ /hr (cubic meters per hour)	1000	4.403	3.666	151.0	—
m ³ /s (cubic meters per seconds)	3.6×10^6	0.02917	0.02429	—	0.006624
kg/hr (kilograms per hour)	$\frac{1}{G}$	$\frac{1}{227.1G}$	$\frac{1}{272.8G}$	$\frac{0.151}{G}$	$\frac{1}{1000G}$
lb/hr (pounds per hour)	$\frac{1}{2.205G}$	$\frac{1}{500.8G}$	$\frac{1}{601.5G}$	$\frac{1}{14.61G}$	$\frac{1}{2205G}$

Ordering – How to Finalize Valve Selection

Once you have determined the basic type (e.g., 81, 83, etc.) of valve required in Step 1 and determined your required orifice area in Step 2, please refer to the following information to finalize the selection and specification and then order the pressure relief valve best suited for your application.

Pressure and Temperature Rating

Compare your preliminary selected valve type and orifice with the following pressure and temperature rating tables on pages 19-22. This will insure the valve type and orifice meets the process requirements.

Valve Material

Using the pressure and temperature rating tables, you can select the proper body material and soft goods. Keep in mind that proper selection of soft goods also includes chemical compatibility with the process.

Inlet and Outlet - Size and Type

Please refer to the dimensions and weight tables on pages 23-34 for proper size and type.

Bill of Material

Detailed bills of material follow on pages 35-40 to assist finalizing material selection and finally selecting model number.

Ordering – Pressure and Temperature Ratings

Pressure and Temperature Ratings for Orifice Sizes -4 to -8								
Valve Model Type	Seat Material	Temperature Range ²	Set Pressure Range ^{3,5} , psig [barg]					
			-4 Brass	-4 CS & SS	-6 (D) Brass	-6 (D) CS & SS	-8 (E) Brass	-8 (E) CS & SS
83	BUNA-N	-65°F to 275°F [-54°C to 135°C]	20 to 2,000 [1.4 to 137.9]	20 to 2,000 [1.4 to 137.9]	20 to 2,000 [1.4 to 137.9]	20 to 2,000 [1.4 to 137.9]	20 to 2,000 [1.4 to 137.9]	20 to 2,000 [1.4 to 137.9]
83	Viton®	-40°F to 400°F [-40°C to 204°C]	20 to 2,000 [1.4 to 137.9]	20 to 2,000 [1.4 to 137.9]	20 to 2,000 [1.4 to 137.9]	20 to 2,000 [1.4 to 137.9]	20 to 2,000 [1.4 to 137.9]	20 to 2,000 [1.4 to 137.9]
83	EPR	-65°F to 300°F [-54°C to 149°C]	20 to 2,000 [1.4 to 137.9]	20 to 2,000 [1.4 to 137.9]	20 to 2,000 [1.4 to 137.9]	20 to 2,000 [1.4 to 137.9]	20 to 2,000 [1.4 to 137.9]	20 to 2,000 [1.4 to 137.9]
83	Kalrez®	-0°F to 550°F [-18°C to 288°C]	20 to 2,000 [1.4 to 137.9]	20 to 2,000 [1.4 to 137.9]	20 to 2,000 [1.4 to 137.9]	20 to 2,000 [1.4 to 137.9]	20 to 2,000 [1.4 to 137.9]	20 to 2,000 [1.4 to 137.9]
81	Teflon®	-423°F to 400°F [-256°C to 204°C]	100 to 1,000 [6.9 to 69.0]	100 to 1,000 [6.9 to 69.0]	100 to 900 [6.9 to 62.1]	100 to 900 [6.9 to 62.1]	50 to 900 [3.4 to 62.1]	50 to 900 [3.4 to 62.1]
81	PCTFE	-423°F to 300°F [-256°C to 149°C]	1,001 to 4,000 [69.1 to 275.8]	1,001 to 4,000 [69.1 to 275.8]	901 to 1,500 [62.2 to 103.4]	901 to 1,500 [62.2 to 103.4]	901 to 1,500 [62.2 to 103.4]	901 to 1,500 [62.2 to 103.4]
81	VespeI	-423°F to 500°F [-256°C to 260°C]	— —	4,001 to 10,000 [276.1 to 689.5]	1,501 to 4,740 [103.5 to 326.8]	1,501 to 9,600 [103.5 to 661.9]	1,501 to 4,000 [103.5 to 275.8]	1,501 to 6,000 [103.5 to 413.7]
81P	Teflon® ¹	-65°F to 400°F [-54°C to 204°C]	50 to 2,000 [3.4 to 137.9]	50 to 2,000 [3.4 to 137.9]	— —	— —	50 to 2,000 [3.4 to 137.9]	50 to 2,000 [3.4 to 137.9]
81P	PCTFE ¹	-65°F to 300°F [-54°C to 149°C]	2,001 to 4,000 [138.1 to 275.8]	2,001 to 6,000 [138.1 to 413.7]	— —	— —	2,001 to 4,000 [138.1 to 275.8]	2,001 to 4,000 [138.1 to 275.8]
86	Teflon®	-423°F to 400°F [-256°C to 204°C]	50 to 235 [3.4 to 16.2]	50 to 235 [3.4 to 16.2]	— —	— —	50 to 177 [3.4 to 12.2]	50 to 177 [3.4 to 12.2]
86	PEEK	-85°F to 515°F [-65°C to 269°C]	236 to 720 [16.3 to 49.7]	236 to 720 [16.3 to 49.7]	— —	— —	178 to 720 [12.3 to 49.7]	178 to 720 [12.3 to 49.7]

Notes

- Minimum temperature is based on elastomer spindle and guide seals.
- Temperature range is limited according to body material of construction as follows:
 Brass: -325F to 406°F
 [-198°C to 208°C]
 CS: -20°F to 550°F
 [-29°C to 288°C]
 SS: -423°F to 550°F
 [-253°C to 288°C].
- Maximum set pressure limited for NACE option as follows:
 Type 81-6: 7100 psig maximum
 Type 81-8: 3120 psig maximum
- Set pressure range for -8(E) orifice as follows:
 -8: Set pressure up to 4000 psig [276 barg]
 (Types 81, 83, 86 and 81P)
 -E: Set pressure over 4000 psig [276 barg]
 (Types 81 and 81P)

Ordering – Pressure and Temperature Ratings

Pressure and Temperature Ratings for Orifice Sizes F to J

Valve Model Type	Seat Material	Temperature Range ²	Brass - Set Pressure Range, psig [barg]			
			F	G	H	J
83	BUNA-N	-65°F to 275°F [-54°C to 135°C]	20 to 2,000 [1.4 to 137.9]	20 to 2,000 [1.4 to 137.9]	20 to 2,000 [1.4 to 137.9]	20 to 1,620 [1.4 to 111.7]
83	Viton®	-40°F to 400°F [-40°C to 205°C]	20 to 2,000 [1.4 to 137.9]	20 to 2,000 [1.4 to 137.9]	20 to 2,000 [1.4 to 137.9]	20 to 1,620 [1.4 to 111.7]
83	EPR	-65°F to 300°F [-54°C to 149°C]	20 to 2,000 [1.4 to 137.9]	20 to 2,000 [1.4 to 137.9]	20 to 2,000 [1.4 to 137.9]	20 to 1,620 [1.4 to 111.7]
83	Kalrez®	-0°F to 550°F [-18°C to 288°C]	20 to 2,000 [1.4 to 137.9]	20 to 2,000 [1.4 to 137.9]	20 to 2,000 [1.4 to 137.9]	20 to 1,620 [1.4 to 111.7]
81	Teflon®	-423°F to 400°F [-253°C to 205°C]	50 to 500 [3.5 to 34.5]	50 to 500 [3.5 to 34.5]	50 to 500 [3.5 to 34.5]	50 to 500 [3.5 to 34.5]
81	PCTFE	-423°F to 300°F [-253°C to 149°C]	501 to 750 [34.5 to 51.7]	501 to 750 [34.5 to 51.7]	501 to 750 [34.5 to 51.7]	501 to 750 [34.5 to 51.7]
81	Vespel	-423°F to 500°F [-253°C to 260°C]	751 to 2,990 [51.8 to 206.2]	751 to 2,570 [51.8 to 177.2]	751 to 2,270 [51.8 to 156.5]	751 to 1,620 [51.8 to 111.7]
81P	Teflon® ¹	-65°F to 400°F [-54°C to 205°C]	— —	50 to 1,000 [3.5 to 69.0]	— —	50 to 1,000 [3.5 to 69.0]
81P	PCTFE ¹	-65°F to 300°F [-54°C to 149°C]	— —	1,001 to 2,570 [69.0 to 177.2]	— —	1,001 to 1,620 [69.0 to 111.7]
86	Teflon®	-423°F to 400°F [-253°C to 205°C]	— —	50 to 151 [3.5 to 10.4]	— —	50 to 95 [3.5 to 6.5]
86	PEEK	-85°F to 515°F [-65°C to 268°C]	— —	152 to 720 [10.5 to 49.7]	— —	96 to 720 [6.6 to 49.7]

Notes

1. Minimum temperature is based on elastomer spindle seals.
2. Temperature range is limited according to body material of construction as follows:
 Brass: -325F to 406°F
 [-198°C to 208°C]
 CS: -20°F to 550°F
 [-29°C to 288°C]
 SS: -423°F to 550°F
 [-253°C to 288°C].

Ordering – Pressure and Temperature Ratings

Pressure and Temperature Ratings for Orifice Sizes F to J						
Valve Model Type	Seat Material	Temperature Range ²	CS and SS - Set Pressure Range, psig [barg]			
			F	G	H	J
83	BUNA-N	-65°F to 275°F [-54°C to 135°C]	20 to 2,000 [1.4 to 137.9]	20 to 2,000 [1.4 to 137.9]	20 to 2,000 [1.4 to 137.9]	20 to 1,620 [1.4 to 111.7]
83	Viton®	-40°F to 400°F [-40°C to 205°C]	20 to 2,000 [1.4 to 137.9]	20 to 2,000 [1.4 to 137.9]	20 to 2,000 [1.4 to 137.9]	20 to 1,620 [1.4 to 111.7]
83	EPR	-65°F to 300°F [-54°C to 149°C]	20 to 2,000 [1.4 to 137.9]	20 to 2,000 [1.4 to 137.9]	20 to 2,000 [1.4 to 137.9]	20 to 1,620 [1.4 to 111.7]
83	Kalrez®	0°F to 550°F [-18°C to 288°C]	20 to 2,000 [1.4 to 137.9]	20 to 2,000 [1.4 to 137.9]	20 to 2,000 [1.4 to 137.9]	20 to 1,620 [1.4 to 111.7]
81	Teflon®	-423°F to 400°F [-253°C to 205°C]	50 to 500 [3.5 to 34.5]	50 to 500 [3.5 to 34.5]	50 to 500 [3.5 to 34.5]	50 to 500 [3.5 to 34.5]
81	PCTFE	-423°F to 300°F [-253°C to 149°C]	501 to 750 [34.5 to 51.7]	501 to 750 [34.5 to 51.7]	501 to 750 [34.5 to 51.7]	501 to 750 [34.5 to 51.7]
81	VespeI	-423°F to 500°F [-253°C to 260°C]	751 to 4,040 [51.8 to 278.6]	751 to 2,570 [51.8 to 177.2]	751 to 2,580 [51.8 to 177.9]	751 to 1,620 [51.8 to 111.7]
81P	Teflon® ¹	-65°F to 400°F [-54°C to 205°C]	— —	50 to 1,000 [3.5 to 69.0]	— —	50 to 1,000 [3.5 to 69.0]
81P	PCTFE ¹	-65°F to 300°F [-54°C to 149°C]	— —	1,001 to 6,000 [69.0 to 413.7]	— —	1,001 to 1,620 [69.0 to 111.7]
86	Teflon®	-423°F to 400°F [-253°C to 205°C]	— —	50 to 151 [3.5 to 10.4]	— —	50 to 95 [3.5 to 6.5]
86	PEEK	-85°F to 515°F [-65°C to 268°C]	— —	152 to 720 [10.5 to 49.7]	— —	96 to 720 [6.6 to 49.7]

Notes

- Minimum temperature is based on elastomer spindle seals.
- Temperature range is limited according to body material of construction as follows:
 Brass: -325F to 406°F
 [-198°C to 208°C]
 CS: -20°F to 550°F
 [-29°C to 288°C]
 SS: -423°F to 550°F
 [-253°C to 288°C].

Ordering – Pressure and Temperature Ratings

Pressure and Temperature Ratings

Valve Model Type	Seat Material	Temperature Range	Set Pressure Range, psig [barg]
61	Teflon®	-325°F to 400°F [-198°C to 205°C]	30 to 500 [2.1 to 34.5]

Pressure and Temperature Ratings

Valve Model Type	Seat Material	Temperature Range	Set Pressure Range, psig [barg]	
			-5	-7
63B	BUNA-N	-65°F to 275°F [-54°C to 135°C]	37 to 531 [2.6 to 36.6]	45 to 374 [3.1 to 25.9]
63B	Viton®	-40°F to 400°F [-40°C to 205°C]	37 to 531 [2.6 to 36.6]	45 to 374 [3.1 to 25.9]
63B	EPR	-65°F to 300°F [-54°C to 149°C]	37 to 531 [2.6 to 36.6]	45 to 374 [3.1 to 25.9]

Ordering – Dimensions and Weights

Dimensions and Weights for -4 Orifice												
Valve Model Type	Body Material	Set Pressure Range	Valve Connections				Threaded Connections		Dimensions			Approx. Weight lb [kg]
			Inlet		Outlet		Inlet	Outlet	A	B	C max ²	
			in	[mm]	in	[mm]			in [mm]	in [mm]	in [mm]	
81, 83	Brass, CS, SS	20 to 4,000 psig [1.4 to 276 barg] ¹	1/2	[15]	3/4 & 1	[18 & 25]	FNPT	FNPT	2.90 [74]	1.50 [38]	9.55 [243]	4.3 [2.0]
			1/2	[15]	3/4 & 1	[18 & 25]	MNPT	FNPT	2.90 [74]	1.50 [38]	9.55 [243]	4.3 [2.0]
			3/4	[18]	3/4 & 1	[18 & 25]	FNPT	FNPT	3.07 [78]	1.50 [38]	9.72 [247]	4.3 [2.0]
			3/4	[18]	3/4 & 1	[18 & 25]	MNPT	FNPT	2.90 [74]	1.50 [38]	9.55 [243]	4.3 [2.0]
			1	[25]	1	[25]	MNPT	FNPT	3.07 [78]	1.50 [38]	9.72 [247]	4.3 [2.0]
81	CS, SS	4,001 to 10,000 psig [276.1 to 690 barg]	3/4 & 1	[18 & 25]	1	[25]	FNPT	FNPT	3.70 [94]	1.81 [46]	14.10 [358]	13.3 [6.1]
			3/4 & 1	[18 & 25]	1	[25]	MNPT	FNPT	3.80 [97]	1.81 [46]	14.20 [361]	13.3 [6.1]
86	Brass, CS, SS	50 to 720 psig [3.4 to 49.7 barg]	1/2	[15]	3/4 & 1	[18 & 25]	FNPT	FNPT	2.90 [74]	1.50 [38]	10.46 [266]	4.5 [2.1]
			1/2	[15]	3/4 & 1	[18 & 25]	MNPT	FNPT	2.90 [74]	1.50 [38]	10.46 [266]	4.5 [2.1]
			3/4	[18]	3/4 & 1	[18 & 25]	FNPT	FNPT	3.07 [78]	1.50 [38]	10.63 [270]	4.5 [2.1]
			3/4	[18]	3/4 & 1	[18 & 25]	MNPT	FNPT	2.90 [74]	1.50 [38]	10.46 [266]	4.5 [2.1]
			1	[25]	1	[25]	MNPT	FNPT	3.07 [78]	1.50 [38]	10.63 [270]	4.5 [2.1]
81P	Brass, CS, SS	50 to 1,160 psig [3.4 to 80 barg]	3/4 & 1	[18 & 25]	1	[25]	FNPT	FNPT	3.70 [94]	1.81 [46]	10.87 [276]	8.3 [3.8]
			3/4 & 1	[18 & 25]	1	[25]	MNPT	FNPT	3.80 [97]	1.81 [46]	10.95 [278]	8.3 [3.8]
81P	Brass, CS, SS	1,161 to 6,000 psig [80.1 to 414 barg]	3/4 & 1	[18 & 25]	1	[25]	FNPT	FNPT	3.70 [94]	1.81 [46]	14.10 [358.1]	13.8 [6.3]
			3/4 & 1	[18 & 25]	1	[25]	MNPT	FNPT	3.80 [97]	1.81 [46]	14.20 [360.7]	13.8 [6.3]

Notes

1. Normal set pressure range for Type 81: 100 to 4,000 psig [6.9 to 275.8 barg]; Type 83: 20 to 2,000 psig [1.4 to 137.9 barg].
2. Add 0.90" [23 mm] to "C max" dimension for numbered orifice Type 81, 83, 86 and 81P with packed lift lever option.

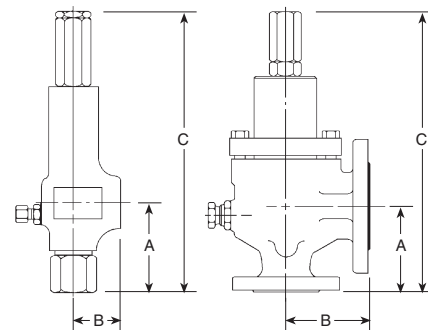

Ordering – Dimensions and Weights

Types 81, 83, 86 and 81P Flanged Connections for -4 Orifice SRVs, CS and SS Body Material

Valve Size in [mm]	Set Pressure Range	Dimensions ^{5,6}		ANSI Inlet Flange ⁷					
				150#	300#	600#	900#	1500#	2500#
1/2 x 1 [15 x 25]	20 to 4,000 psig [1.4 to 275.8 barg] ^{1, 2, 3}	A	in [mm]	4.82 [122]	4.82 [122.4]	4.97 [126.2]	4.97 [126.2]	4.97 [126.2]	5.97 [151.6]
		B	in [mm]	4.75 [121]	4.75 [120.6]	4.75 [120.6]	4.75 [120.6]	4.75 [120.6]	6.75 [171.4]
		C	in [mm]	12.12 [308]	12.12 [308]	12.27 [312]	12.27 [312]	12.27 [312]	13.27 [337]
		max	in [mm]						
		Wt.	lb [kg]	12.0 [5.5]	13.0 [5.9]	13.0 [5.9]	15.0 [6.8]	15.0 [6.8]	19.0 [8.6]
1/2 x 1 [15 x 25]	4,001 to 6,000 psig [275.9 to 413.7 barg] ⁴	A	in [mm]	—	—	—	—	—	5.97 [151.6]
		B	in [mm]	—	—	—	—	—	6.75 [171.4]
		C	in [mm]	—	—	—	—	—	16.47 [418.3]
		max	in [mm]	—	—	—	—	—	24.0 [609.6]
		Wt.	lb [kg]	—	—	—	—	—	10.9 [4.9]
3/4 x 1 [18 x 25]	20 to 4,000 psig [1.4 to 275.8 barg] ^{1, 2, 3}	A	in [mm]	4.72 [120]	4.72 [120]	4.72 [120]	4.72 [120]	4.72 [120]	5.72 [145.3]
		B	in [mm]	4.75 [121]	4.75 [121]	4.75 [121]	4.75 [121]	4.75 [121]	6.75 [171.4]
		C	in [mm]	12.02 [305]	12.02 [305]	12.02 [305]	12.02 [305]	12.02 [305]	13.02 [331]
		max	in [mm]						
		Wt.	lb [kg]	13.0 [5.9]	14.0 [6.4]	14.0 [6.4]	17.0 [7.7]	17.0 [7.7]	20.0 [9.1]
3/4 x 1 [18 x 25]	4,001 to 6,000 psig [275.9 to 413.7 barg] ⁴	A	in [mm]	—	—	—	—	—	5.72 [145.3]
		B	in [mm]	—	—	—	—	—	6.75 [171.4]
		C	in [mm]	—	—	—	—	—	16.22 [412.0]
		max	in [mm]	—	—	—	—	—	25.0 [635.0]
		Wt.	lb [kg]	—	—	—	—	—	11.3 [5.1]

Ordering – Dimensions and Weights

Types 81, 83, 86 and 81P Flanged Connections for -4 Orifice SRVs, CS and SS Body Material - continued

Valve Size in [mm]	Set Pressure Range	Dimensions ^{5,6}		ANSI Inlet Flange ⁷					
				150#	300#	600#	900#	1500#	2500#
1 x 1 [25 x 25]	20 to 4,000 psig [1.4 to 275.8 barg] ^{1, 2, 3}	A	in [mm]	4.72 [120]	4.72 [120]	4.72 [120]	5.72 [145.3]	5.72 [145.3]	5.72 [145.3]
		B	in [mm]	4.75 [121]	4.75 [121]	4.75 [121]	6.75 [171.4]	6.75 [171.4]	6.75 [171.4]
		C	in [mm]	12.02 [305]	12.02 [305]	12.02 [305]	13.02 [331]	13.02 [331]	13.02 [331]
		max	in [mm]	13.0 [305]	14.0 [305]	15.0 [305]	20.0 [331]	20.0 [331]	23.0 [331]
		Wt.	lb [kg]	13.0 [5.9]	14.0 [6.4]	15.0 [6.8]	20.0 [9.1]	20.0 [9.1]	23.0 [10.5]
1 x 1 [25 x 25]	4,001 to 6,000 psig [275.9 to 413.7 barg] ⁴	A	in [mm]	—	—	—	—	—	5.72 [145.3]
		B	in [mm]	—	—	—	—	—	6.75 [171.5]
		C	in [mm]	—	—	—	—	—	16.22 [412.0]
		max	in [mm]	—	—	—	—	—	28.0 [711.0]
		Wt.	lb [kg]	—	—	—	—	—	28.0 [12.7]

Notes

- Normal set pressure range for Type 81: 100 to 4,000 psig [6.9 to 275.8 barg].
- Set pressure range for Type 86: 50 to 720 psig [3.5 to 49.6 barg].
- Set pressure range for Type 81P: 50 to 1,160 psig [3.5 to 80.0 barg].
- Set pressure range for Type 81P: 1,161 to 6,000 psig [80.1 to 413.7 barg].
- Add 0.90" [23 mm] to "C max" dimension for numbered orifice Types 81, 83, 86 and 81P with packed lift lever option.
- Dimensions listed are for connection sizes with slip-on flanges. For other connection sizes and types, or for weld neck flanges, consult your sales representative for dimensions.
- Dimensions do not vary with outlet flange ratings.

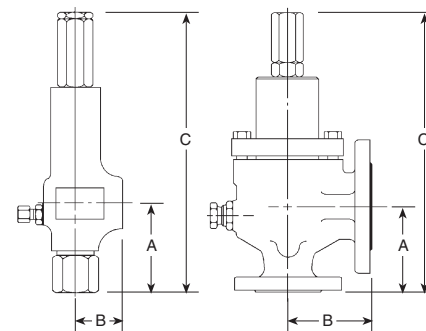

Ordering – Dimensions and Weights

Dimensions and Weights for -6 (D) Orifice

Valve Model Type	Body Material	Set Pressure Range	Valve Connections		Threaded Connections		Dimensions			Approx. Weight lb [kg]						
			Inlet in [mm]	Outlet in [mm]	Inlet Outlet	A in [mm]	B in [mm]	C max ² in [mm]								
81, 83	Brass	20 to 1,410 psig	1/2, 3/4 & 1	[15, 18 & 25]	1	[25]	FNPT	FNPT	3.70	[94]	1.81	[46]	10.99	[279]	8.3	[3.8]
	CS, SS	[1.4 to 97.2 barg] ¹	3/4 & 1	[18 & 25]	1	[25]	MNPT	FNPT	3.80	[97]	1.81	[46]	10.99	[279]	8.3	[3.8]
81, 83	Brass	1,411 to 9,600 psig	1/2, 3/4 & 1	[15, 18 & 25]	1	[25]	FNPT	FNPT	3.70	[94]	1.81	[46]	14.18	[360]	13.3	[6.0]
	CS, SS	[97.3 to 662 barg]	3/4 & 1	[18 & 25]	1	[25]	MNPT	FNPT	3.80	[97]	1.81	[46]	14.20	[361]	13.3	[6.0]

Notes

1. Normal set pressure range for Type 81: 100 to 1,410 psig [6.9 to 97.2 barg]
2. Add 0.90" [23 mm] to "C max" dimension for numbered orifice Types 81 and 83 with packed lift lever option.

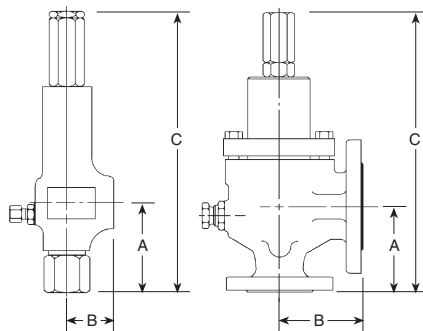

Ordering – Dimensions and Weights

Types 81 and 83 Flanged Connections for -6 (D) Orifice SRVs, CS and SS Body Material (continued on page 28)

Valve Size in [mm]	Set Pressure Range	Dimensions ^{2,3}		ANSI Inlet Flange ⁴					
				150#	300#	600#	900#	1500#	2500#
1/2 x 1 [15 x 25]	20 to 1,410 psig [1.4 to 97.2 barg] ¹	A	in [mm]	4.82 [122]	4.82 [122]	4.97 [126]	4.97 [126]	4.97 [126]	5.97 [152]
		B	in [mm]	4.75 [121]	4.75 [121]	4.75 [121]	4.75 [121]	4.75 [121]	6.75 [172]
		C	in [mm]	12.12 [308]	12.12 [308]	12.27 [312]	12.27 [312]	12.27 [312]	13.27 [337]
		max	in [mm]	12.12 [308]	12.12 [308]	12.27 [312]	12.27 [312]	12.27 [312]	13.27 [337]
		Wt.	lb [kg]	12.0 [5.4]	13.0 [5.9]	13.0 [5.9]	15.0 [6.8]	15.0 [6.8]	19.0 [8.6]
1/2 x 1 [15 x 25]	1,411 to 6,000 psig [97.3 to 413.7 barg]	A	in [mm]	—	—	4.97 [126]	4.97 [126]	4.97 [126]	5.97 [152]
		B	in [mm]	—	—	4.75 [121]	4.75 [121]	4.75 [121]	6.75 [172]
		C	in [mm]	—	—	15.47 [393]	15.47 [393]	15.47 [393]	16.47 [418]
		max	in [mm]	—	—	15.47 [393]	15.47 [393]	15.47 [393]	16.47 [418]
		Wt.	lb [kg]	—	—	18.0 [8.2]	20.0 [9.1]	20.0 [9.1]	24.0 [10.9]
3/4 x 1 [18 x 25]	20 to 1,410 psig [1.4 to 97.2 barg] ¹	A	in [mm]	4.72 [120]	4.72 [120]	4.72 [120]	4.72 [120]	4.72 [120]	5.72 [145]
		B	in [mm]	4.75 [121]	4.75 [121]	4.75 [121]	4.75 [121]	4.75 [121]	6.75 [172]
		C	in [mm]	12.02 [305]	12.02 [305]	12.02 [305]	12.02 [305]	12.02 [305]	13.02 [331]
		max	in [mm]	12.02 [305]	12.02 [305]	12.02 [305]	12.02 [305]	12.02 [305]	13.02 [331]
		Wt.	lb [kg]	13.0 [5.9]	14.0 [6.4]	14.0 [6.4]	17.0 [7.7]	17.0 [7.7]	20.0 [9.1]
3/4 x 1 [18 x 25]	1,411 to 6,000 psig [97.3 to 413.7 barg]	A	in [mm]	—	—	4.72 [120]	4.72 [120]	4.72 [120]	5.72 [145]
		B	in [mm]	—	—	4.75 [121]	4.75 [121]	4.75 [121]	6.75 [172]
		C	in [mm]	—	—	15.22 [387]	15.22 [387]	15.22 [387]	16.22 [387]
		max	in [mm]	—	—	15.22 [387]	15.22 [387]	15.22 [387]	16.22 [387]
		Wt.	lb [kg]	—	—	19.0 [8.6]	22.0 [10.0]	22.0 [10.0]	25.0 [11.3]

Notes

- Normal set pressure range for Type 81: 100 to 1,410 psig [6.9 to 97 barg].
- Add 0.90" [23 mm] to "C max" dimension for numbered orifice Types 81 and 83 with packed lift lever option.
- Dimensions listed are for connection sizes with slip-on flanges. For other connection sizes and types, or for weld neck flanges, consult your sales representative for dimensions.
- Dimensions do not vary with outlet flange pressure rating.

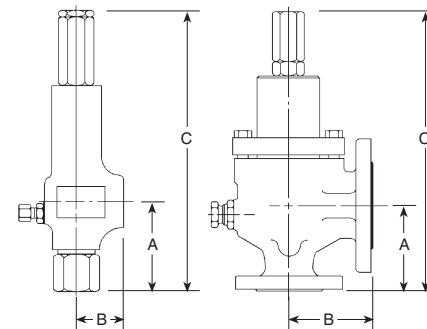

Ordering – Dimensions and Weights

Types 81 and 83 Flanged Connections for -6 (D) Orifice SRVs, CS and SS Body Material - continued

Valve Size in [mm]	Set Pressure Range	Dimensions ^{2,3}		ANSI Inlet Flange ⁴					
				150#	300#	600#	900#	1500#	2500#
1 x 1 [25 x 25]	20 to 1,410 psig [1.4 to 97.2 barg] ¹	A	in [mm]	4.72 [120]	4.72 [120]	4.72 [120]	5.72 [145]	5.72 [145]	5.72 [145]
		B	in [mm]	4.75 [121]	4.75 [121]	4.75 [121]	6.75 [172]	6.75 [172]	6.75 [172]
		C	in [mm]	12.02 [305]	12.02 [305]	12.02 [305]	13.02 [331]	13.02 [331]	13.02 [331]
		max	in [mm]	12.02 [305]	12.02 [305]	12.02 [305]	13.02 [331]	13.02 [331]	13.02 [331]
		Wt.	lb [kg]	13.0 [5.9]	14.0 [6.4]	15.0 [6.8]	20.0 [9.1]	20.0 [9.1]	23.0 [10.5]
1 x 1 [25 x 25]	1,411 to 6,000 psig [97.3 to 413.7 barg]	A	in [mm]	—	—	4.72 [120]	5.72 [145]	5.72 [145]	5.72 [145]
		B	in [mm]	—	—	4.75 [121]	6.75 [172]	6.75 [172]	6.75 [172]
		C	in [mm]	—	—	15.22 [387]	16.22 [412]	16.22 [412]	16.22 [412]
		max	in [mm]	—	—	15.22 [387]	16.22 [412]	16.22 [412]	16.22 [412]
		Wt.	lb [kg]	—	—	20.0 [9.1]	25.0 [11.4]	25.0 [11.4]	28.0 [12.7]

Notes

- Normal set pressure range for Type 81: 100 to 1,410 psig [6.9 to 97 barg].
- Add 0.90" [23 mm] to "C max" dimension for numbered orifice Types 81 and 83 with packed lift lever option.
- Dimensions listed are for connection sizes with slip-on flanges. For other connection sizes and types, or for weld neck flanges, consult your sales representative for dimensions.
- Dimensions do not vary with outlet flange pressure rating.

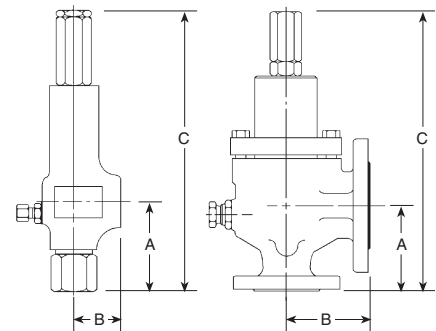

Ordering – Dimensions and Weights

Dimensions and Weights for -8 (E) Orifice

Valve Model Type	Body Material	Set Pressure Range	Valve Connections		Threaded Connections		A in [mm]	Dimensions B in [mm]	C max ² in [mm]	Approx. Weight lb [kg]		
			Inlet in	Outlet [mm]	Inlet in	Outlet [mm]						
81, 83	Brass	20 to 600 psig	3/4 & 1	[18 & 25]	1	[25]	FNPT	FNPT	3.70 [94]	1.81 [46.0]	10.99 [279]	8.3 [3.8]
	CS, SS	[1.4 to 41.4 barg] ¹	3/4 & 1	[18 & 25]	1	[25]	MNPT	FNPT	3.80 [97]	1.81 [46.0]	10.99 [279]	8.3 [3.8]
81, 83	Brass	601 to 4,000 psig	3/4 & 1	[18 & 25]	1	[25]	FNPT	FNPT	3.70 [94]	1.81 [46.0]	14.10 [358]	13.8 [6.3]
	CS, SS	[41.5 to 276 barg]	3/4 & 1	[18 & 25]	1	[25]	MNPT	FNPT	3.80 [97]	1.81 [46.0]	14.20 [361]	13.8 [6.3]
86	Brass	50 to 600 psig	3/4 & 1	[18 & 25]	1	[25]	FNPT	FNPT	3.70 [94]	1.81 [46.0]	11.77 [299]	8.5 [3.9]
	CS, SS	[3.4 to 41.4 barg]	3/4 & 1	[18 & 25]	1	[25]	MNPT	FNPT	3.80 [97]	1.81 [46.0]	11.85 [301]	8.5 [3.9]
86	Brass	601 to 720 psig	3/4 & 1	[18 & 25]	1	[25]	FNPT	FNPT	3.70 [94]	1.81 [46.0]	15.00 [381]	14.0 [6.4]
	CS, SS	[41.5 to 49.7 barg]	3/4 & 1	[18 & 25]	1	[25]	MNPT	FNPT	3.80 [97]	1.81 [46.0]	15.10 [384]	14.0 [6.4]
81P	Brass	50 to 600 psig	3/4 & 1	[18 & 25]	1	[25]	FNPT	FNPT	3.70 [94]	1.81 [46.0]	10.81 [275]	8.3 [3.8]
	CS, SS	[3.4 to 41.4 barg]	3/4 & 1	[18 & 25]	1	[25]	MNPT	FNPT	3.80 [97]	1.81 [46.0]	10.95 [278]	8.3 [3.8]
81P	Brass	601 to 4,000 psig	3/4 & 1	[18 & 25]	1	[25]	FNPT	FNPT	3.70 [94]	1.81 [46.0]	14.10 [358]	13.8 [6.3]
	CS, SS	[41.5 to 276 barg]	3/4 & 1	[18 & 25]	1	[25]	MNPT	FNPT	3.80 [97]	1.81 [46.0]	14.20 [361]	13.8 [6.3]
81, 81P	CS, SS	4,001 to 6,000 psig [276.1 to 414 barg]	1 1/2	[40]	2	[50]	FNPT	FNPT	3.41 [87]	3.50 [89]	19.60 [498]	25.0 [11.4]

Notes

1. Normal set pressure range for Type 81: 50 to 600 psig [3.5 to 41.4 barg].
2. Add 0.90" [23 mm] to "C max" dimension for numbered orifice Types 81, 83, and 81P with packed lift lever option.

Add 2.0" [102 mm] to "C max" dimension for Type 81-E orifice with set pressure range 4,001 to 6,000 psig [276 to 414 barg] with packed lift lever option.

Add 1.75" [45 mm] to "C max" dimension for Type 81P-E orifice with set pressure range 4,001 to 6,000 psig [276 to 414 barg] with packed lift lever option.

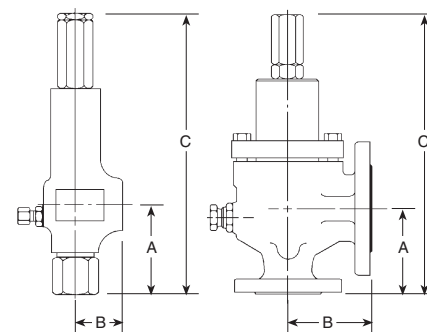

Ordering – Dimensions and Weights

Types 81, 83, 86 and 81P Flanged Connections for -8 (E) Orifice SRVs, CS and SS Body Material

Valve Size in [mm]	Set Pressure Range	Dimensions ^{3,4}		ANSI Inlet Flange ⁵					
				150#	300#	600#	900#	1500#	2500#
$\frac{3}{4}$ x 1 [18 x 25]	20 to 600 psig [1.4 to 41.4 barg] ¹	A	in [mm]	4.72 [120]	4.72 [120]	4.72 [120]	4.72 [120]	4.72 [120]	5.72 [145]
		B	in [mm]	4.75 [121]	4.75 [121]	4.75 [121]	4.75 [121]	4.75 [121]	6.75 [172]
		C	in [mm]	12.02 [305]	12.02 [305]	12.02 [305]	12.02 [305]	12.02 [305]	13.02 [331]
		max							
		Wt.	lb [kg]	13.0 [5.9]	14.0 [6.4]	14.0 [6.4]	17.0 [7.7]	17.0 [7.7]	20.0 [9.1]
$\frac{3}{4}$ x 1 [18 x 25]	601 to 4,000 psig [41.5 to 276 barg] ²	A	in [mm]	—	4.72 [120]	4.72 [120]	4.72 [120]	4.72 [120]	5.72 [145]
		B	in [mm]	—	4.75 [121]	4.75 [121]	4.75 [121]	4.75 [121]	6.75 [172]
		C	in [mm]	—	15.22 [387]	15.22 [387]	15.22 [387]	15.22 [387]	16.22 [412]
		max							
		Wt.	lb [kg]	—	19.0 [8.6]	19.0 [8.6]	22.0 [10.0]	22.0 [10.0]	25.0 [11.4]
1 x 1 [25 x 25]	20 to 600 psig [1.4 to 41.4 barg] ¹	A	in [mm]	4.72 [120]	4.72 [120]	4.72 [120]	5.72 [145]	5.72 [145]	5.72 [145]
		B	in [mm]	4.75 [121]	4.75 [121]	4.75 [121]	6.75 [172]	6.75 [172]	6.75 [172]
		C	in [mm]	12.02 [305.0]	12.02 [305.0]	12.02 [305.0]	13.02 [331]	13.02 [331]	13.02 [331]
		max							
		Wt.	lb [kg]	13.0 [5.9]	14.0 [6.4]	15.0 [6.8]	20.0 [9.1]	20.0 [9.1]	23.0 [10.5]
1 x 1 [25 x 25]	601 to 4,000 psig [41.5 to 276 barg] ²	A	in [mm]	—	4.72 [120]	4.72 [120]	5.72 [145]	5.72 [145]	5.72 [145]
		B	in [mm]	—	4.75 [121]	4.75 [121]	6.75 [172]	6.75 [172]	6.75 [172]
		C	in [mm]	—	15.22 [387]	15.22 [387]	16.22 [412]	16.22 [412]	16.22 [412]
		max							
		Wt.	lb [kg]	—	19.0 [8.6]	20.0 [9.1]	25.0 [11.4]	25.0 [11.4]	28.0 [12.7]

Ordering – Dimensions and Weights

Types 81, 83, 86 and 81P Flanged Connections for -8 (E) Orifice SRVs, CS and SS Body Material - continued

Valve Size in [mm]	Set Pressure Range	Dimensions ^{3,4}		ANSI Inlet Flange ⁵					
				150#	300#	600#	900#	1500#	2500#
1 x 2 [25 x 50]	20 to 600 psig [1.4 to 41.4 barg] ¹	A	in [mm]	4.72 [120]	4.72 [120]	4.72 [120]	5.72 [145]	5.72 [145]	5.72 [145]
		B	in [mm]	4.75 [121]	4.75 [121]	4.75 [121]	6.75 [172]	6.75 [172]	6.75 [172]
		C	in [mm]	12.02 [305]	12.02 [305]	12.02 [305]	13.02 [331]	13.02 [331]	13.02 [331]
		max	in [mm]	12.02 [305]	12.02 [305]	12.02 [305]	13.02 [331]	13.02 [331]	13.02 [331]
		Wt.	lb [kg]	16.0 [7.3]	17.0 [7.7]	18.0 [8.2]	25.0 [11.4]	25.0 [11.4]	28.0 [12.7]
1 x 2 [25 x 50]	601 to 4,000 psig [41.1 to 276 barg] ²	A	in [mm]	— —	4.72 [120]	4.72 [120]	5.72 [145]	5.72 [145]	5.72 [145]
		B	in [mm]	— —	4.75 [121]	4.75 [121]	6.75 [172]	6.75 [172]	6.75 [172]
		C	in [mm]	— —	15.22 [387]	15.22 [387]	16.22 [412]	16.22 [412]	16.22 [412]
		max	in [mm]	— —	15.22 [387]	15.22 [387]	16.22 [412]	16.22 [412]	16.22 [412]
		Wt.	lb [kg]	— —	22.0 [10]	23.0 [10.5]	30.0 [13.6]	30.0 [13.6]	33.0 [15]

Notes

- Normal set pressure range for Types 81, 86 and 81P: 50 to 600 psig [3.5 to 41.4 barg].
- Set pressure range for Type 86: 601 to 720 psig [41.4 to 49.6 barg].
- Add 0.90" [23 mm] to "C max" dimension for numbered orifice Types 81, 83, 86 and 81P with packed lift lever option.
- Dimensions listed are for connection sizes with slip-on flanges. For other connection sizes, or for weld neck flanges, consult your sales representative for dimensions.
- Dimensions do not vary with outlet flange pressure rating.

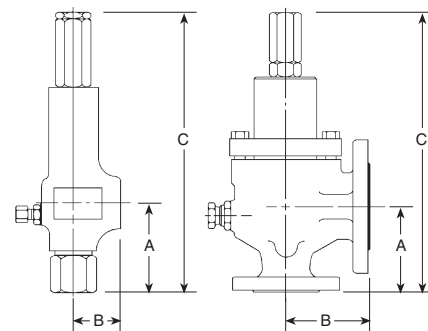

Ordering – Dimensions and Weights

Dimensions and Weights for F Orifice

Valve Model Type	Body Material	Valve Size		Connections		A		Dimensions B		C max ¹		Approx. Weight	
		Inlet	Outlet	Inlet	Outlet	in	[mm]	in	[mm]	in	[mm]	lb	[kg]
81, 83	Brass, CS, SS	1 1/2 x 2	[40 x 50]	FNPT	FNPT	3.41	[87]	3.50	[89]	20.00	[508]	25.0	[11.3]
81, 83	Brass, CS, SS	1 1/2 x 2	[40 x 50]	150	150	4.87	[124]	4.75	[121]	14.48	[368]	29.0	[13.2]
81, 83	Brass, CS, SS	1 1/2 x 2	[40 x 50]	300	150	4.87	[124]	4.75	[121]	16.88	[429]	32.0	[14.5]
81, 83	Brass, CS, SS	1 1/2 x 2	[40 x 50]	600	150	4.87	[124]	4.75	[121]	20.05	[509]	34.0	[15.4]
81, 83	Brass, CS, SS	1 1/2 x 2	[40 x 50]	900	150	5.25	[133]	4.75	[121]	20.43	[519]	39.0	[17.7]
81, 83	Brass, CS, SS	1 1/2 x 2	[40 x 50]	1500	150	5.25	[133]	4.75	[121]	21.79	[554]	40.0	[18.1]
81, 83	Brass, CS, SS	1 1/2 x 2	[40 x 50]	2500	150	5.87	[149]	4.75	[121]	22.41	[569]	53.0	[24.0]

Dimensions and Weights for G Orifice

Valve Model Type	Body Material	Valve Size		Connections		A		Dimensions B		C max ^{1,2,3}		Approx. Weight	
		Inlet	Outlet	Inlet	Outlet	in	[mm]	in	[mm]	in	[mm]	lb	[kg]
81, 83, 86, 81P	Brass, CS, SS	1 1/2 x 2	[40 x 50]	FNPT	FNPT	3.41	[87]	3.50	[89]	20.00	[508]	25.0	[11.3]
81, 83, 86, 81P	Brass, CS, SS	1 1/2 x 2	[40 x 50]	150	150	4.87	[124]	4.75	[121]	16.88	[429]	30.0	[13.6]
81, 83, 86, 81P	Brass, CS, SS	1 1/2 x 2	[40 x 50]	300	150	4.87	[124]	4.75	[121]	20.05	[509]	32.0	[14.5]
81, 83, 86, 81P	Brass, CS, SS	1 1/2 x 2	[40 x 50]	600	150	4.87	[124]	4.75	[121]	20.05	[509]	34.0	[15.4]
81, 83, 86, 81P	Brass, CS, SS	1 1/2 x 2	[40 x 50]	900	150	5.25	[133]	4.75	[121]	21.79	[554]	40.0	[18.1]
81, 83, 86, 81P	Brass, CS, SS	1 1/2 x 2	[40 x 50]	1500	150	5.25	[133]	4.75	[121]	21.79	[554]	40.0	[18.1]
81P	CS	2 x 3	[50 x 80]	FNPT	FNPT	3.80	[97]	4.96	[126]	22.31	[567]	45.0	[20.4]
81P	CS	2 x 3	[50 x 80]	2500	150	8.12	[206]	4.87	[124]	26.10	[663]	72.0	[32.7]

Notes

1. Add 2" [51 mm] to "C max" dimension for lettered orifice Types 81, 83 and 86 with packed lift lever option.
2. Add 1.75" [45 mm] to "C max" dimension for lettered orifice 1 1/2" x 2" [40 mm x 50 mm] Type 81P-G with packed lift lever option.
3. Add 2.39" [61 mm] to "C max" dimension for lettered orifice 2" x 3" [50 mm x 80 mm] Type 81P-G with packed lift lever option.

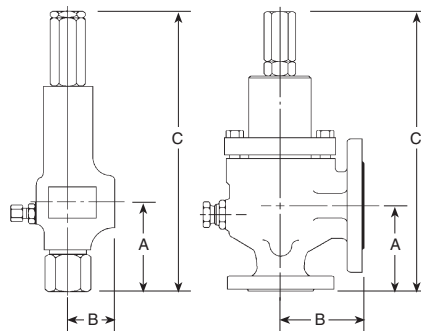

Ordering – Dimensions and Weights

Dimensions and Weights for H Orifice

Valve Model Type	Body Material	Valve Size		Connections		Dimensions			Approx. Weight				
		Inlet	Outlet	Inlet	Outlet	A	B	C max ¹	lb	[kg]			
		in	[mm]			in	[mm]	in	[mm]				
81, 83	CS, SS	1½ x 3	[40 x 80]	150	150	5.58	[142]	4.87	[124]	18.73	[476]	51.0	[23.1]
81, 83	CS, SS	1½ x 3	[40 x 80]	300	150	5.83	[148]	4.87	[124]	19.10	[485]	53.0	[24.0]
81, 83	CS, SS	1½ x 3	[40 x 80]	600	150	6.15	[156]	4.87	[124]	24.15	[614]	55.0	[25.0]
81, 83	CS, SS	1½ x 3	[40 x 80]	900	150	6.75	[172]	4.87	[124]	24.75	[629]	69.0	[31.3]
81, 83	CS, SS	1½ x 3	[40 x 80]	1500	150	6.75	[172]	4.87	[124]	24.75	[629]	69.0	[31.3]
81, 83	Brass, CS, SS	2 x 3	[50 x 80]	FNPT	FNPT	3.80	[97]	4.96	[126]	21.80	[554]	45.0	[20.4]
81, 83	Brass, CS, SS	2 x 3	[50 x 80]	150	150	5.37	[136]	4.87	[124]	18.45	[469]	51.0	[23.1]
81, 83	Brass, CS, SS	2 x 3	[50 x 80]	300	150	5.37	[136]	4.87	[124]	18.45	[469]	53.0	[24.0]
81, 83	Brass, CS, SS	2 x 3	[50 x 80]	600	150	5.37	[136]	4.87	[124]	23.37	[594]	55.0	[25.0]
81, 83	Brass, CS, SS	2 x 3	[50 x 80]	900	150	6.56	[167]	4.87	[124]	24.56	[624]	69.0	[31.3]
81, 83	Brass, CS, SS	2 x 3	[50 x 80]	1500	150	6.56	[167]	4.87	[124]	24.56	[624]	69.0	[31.3]

Dimensions and Weights for J Orifice

Valve Model Type	Body Material	Valve Size		Connections		Dimensions			Approx. Weight				
		Inlet	Outlet	Inlet	Outlet	A	B	C max ^{1,2,3}	lb	[kg]			
		in	[mm]			in	[mm]	in	[mm]				
81, 83, 86, 81P	Brass, CS, SS	2 x 3	[50 x 80]	FNPT	FNPT	3.80	[97]	4.96	[126]	21.80	[554]	45.0	[20.4]
81, 83, 86, 81P	Brass, CS, SS	2 x 3	[50 x 80]	150	150	5.37	[136]	4.87	[124]	18.45	[469]	51.0	[23.1]
81, 83, 86, 81P	Brass, CS, SS	2 x 3	[50 x 80]	300	150	5.37	[136]	4.87	[124]	23.37	[594]	55.0	[25.0]
81, 83, 86, 81P	Brass, CS, SS	2 x 3	[50 x 80]	600	150	5.37	[136]	4.87	[124]	23.37	[594]	55.0	[25.0]
81, 83, 86, 81P	Brass, CS, SS	2 x 3	[50 x 80]	900	150	6.56	[167]	4.87	[124]	24.56	[624]	69.0	[31.3]
81, 83, 86, 81P	Brass, CS, SS	2 x 3	[50 x 80]	1500	150	6.56	[167]	4.87	[124]	24.56	[624]	69.0	[31.3]

Notes

1. Add 2.0" [51 mm] to "C max" dimension for lettered orifice Types 81, 83 and 86 with packed lift lever option.
2. Add 2.39" [61 mm] to "C max" dimension for lettered orifice 2" x 3" [50 mm x 80 mm] Type 81P-J with packed lift lever option.
3. "C max" dimension for 2" x 3" [50 mm x 80 mm] Type 81P-J orifice with FNPT connections is 22.31" [567 mm].

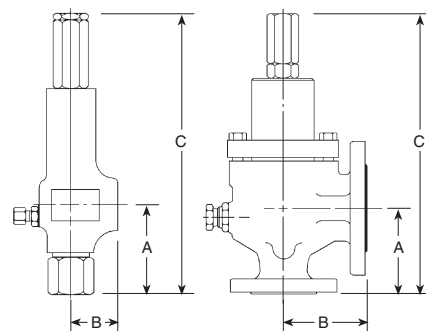

Ordering – Dimensions and Weights Types 61 and 63B

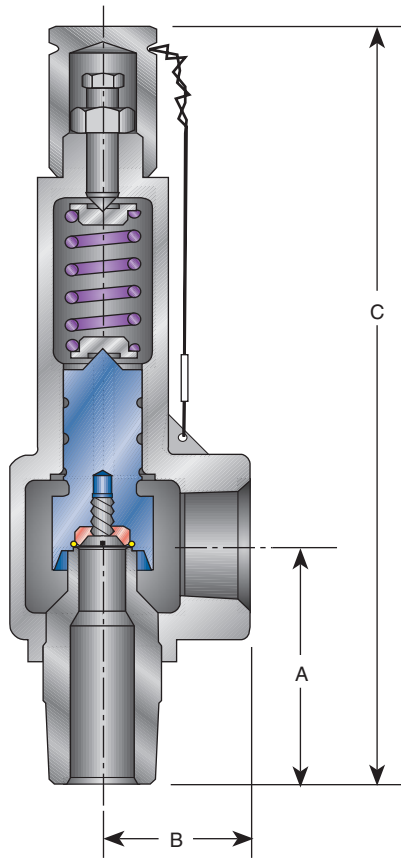

Dimensions and Weights for -5 Orifice, Brass Body

Valve Model Type	Set Pressure Range	Valve Connections in [mm]		Threaded Connections		A in [mm]	Dimensions B in [mm]	C max in [mm]	Approx. Weight lb [kg]
		Inlet	Outlet	Inlet	Outlet				
63B	37 to 531 psig [2.6 to 36.6 barg]	1/2 [15]	1 [25]	FNPT	FNPT	2.25 [57]	1.38 [35]	7.31 [186]	2.5 [1.1]
63B	37 to 531 psig [2.6 to 36.6 barg]	1/2 [15]	1 [25]	MNPT	FNPT	2.25 [57]	1.38 [35]	7.31 [186]	2.5 [1.1]
63B	37 to 531 psig [2.6 to 36.6 barg]	3/4 [18]	1 [25]	MNPT	FNPT	2.25 [57]	1.38 [35]	7.31 [186]	2.5 [1.1]

Dimensions and Weights for -6 Orifice, Brass Body

Valve Model Type	Set Pressure Range	Valve Connections in [mm]		Threaded Connections		A in [mm]	Dimensions B in [mm]	C max in [mm]	Approx. Weight lb [kg]
		Inlet	Outlet	Inlet	Outlet				
61	30 to 500 psig [2.1 to 34.5 barg]	1/2 [15]	1 [25]	MNPT	FNPT	2.25 [57]	1.38 [35]	7.31 [186]	2.5 [1.1]

Dimensions and Weights for 7 Orifice, Brass Body

Valve Model Type	Set Pressure Range	Valve Connections in [mm]		Threaded Connections		A in [mm]	Dimensions B in [mm]	C max in [mm]	Approx. Weight lb [kg]
		Inlet	Outlet	Inlet	Outlet				
63B	45 to 374 psig [3.1 to 25.8 barg]	3/4 [18]	1 [25]	MNPT	FNPT	2.25 [57]	1.38 [35]	7.31 [186]	2.5 [1.1]

Ordering – Types 61 and 63B Materials of Construction

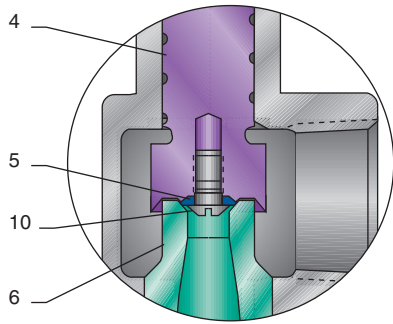

Type 61

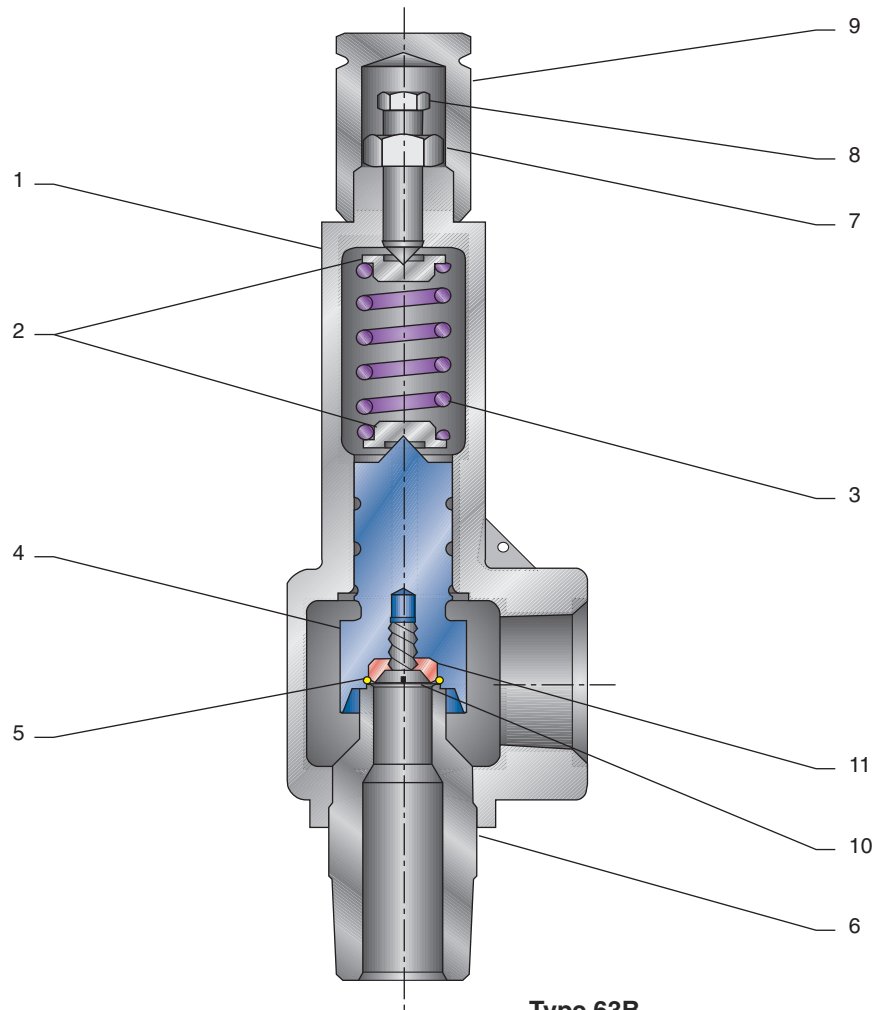

Type 63B

Note

- 1. Standard seat material.

Standard Materials

Item No.	Part Name	Material
1	Body	BRS SB62
2	Spring Washer	A582 303 SS
3	Spring	316 SS or 17-7 PH SS
4	Spindle	A582 303 SS (Type 63B) BRS B16 (Type 61)
5	Seat	BUNA-N ¹ , Viton [®] , EPR (Type 63B) PTFE ¹ (Type 61)
6	Nozzle	BRS B16
7	Lock Nut	A307 Steel (Type 63B) Brass (Type 61)
8	Pressure Adjustment Screw	A108 12L14 CS (Type 63B) BRS B16 (Type 61)
9	Cap	BRS B16
10	Seat Retainer Screw	316 SS (Type 63B) 17-4 PH SS (Type 61)
11	Seat Retainer	A582 303 SS (Type 63B)

Ordering – Types 81, 83, 86 and 81P Materials of Construction

Orifice Sizes -4 to -8

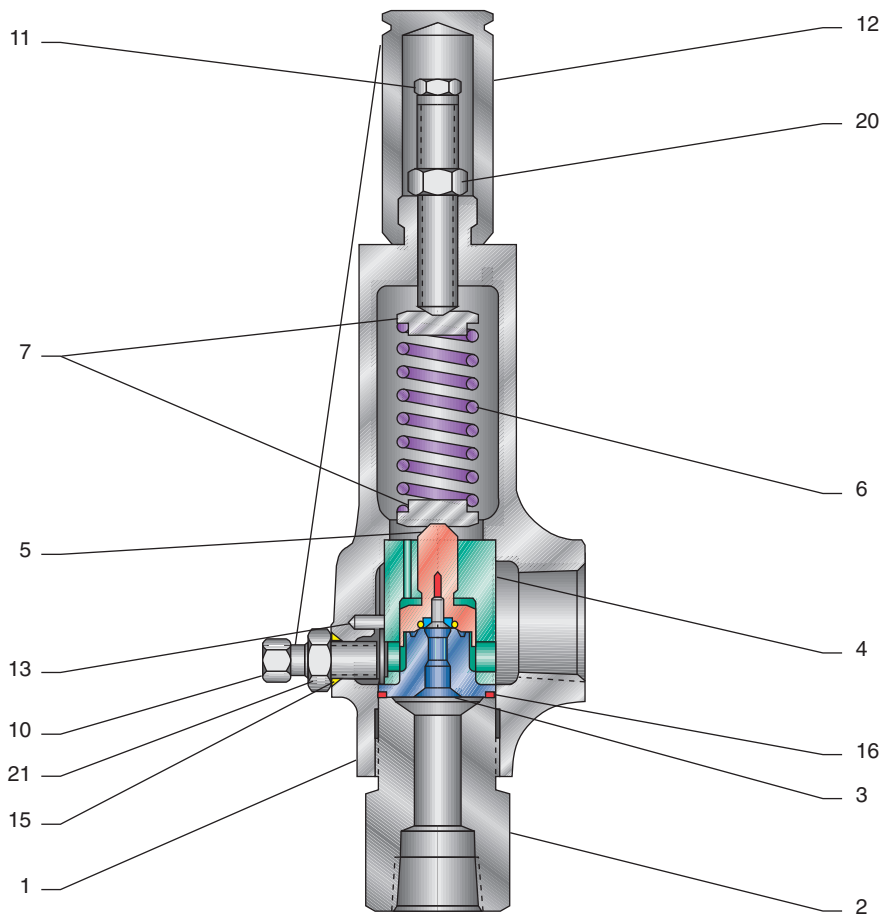

81P Seat (plastic)

83 Seat (O-ring)

81 and 86 Seat (plastic)

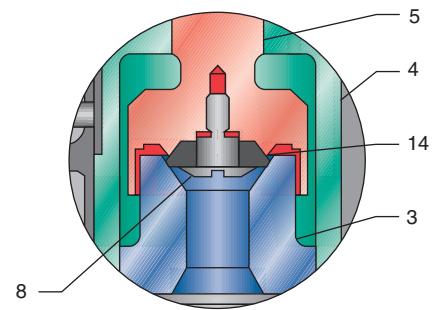
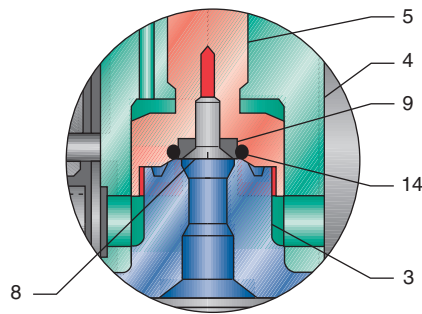
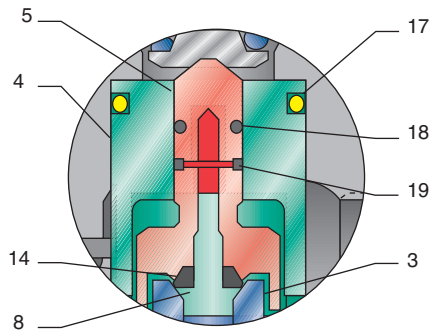

Ordering – Types 81, 83, 86 and 81P Materials of Construction

Standard Materials¹ - Types 81, 83, 86 and 81P for Orifice Sizes -4 to -8

Item No.	Part Name	Bronze/Brass	CS ²	SS ²
1	Body	Br. SB62	SA216 WCB CS	SA351-CF8M SS
2	Inlet Bushing	Br. B16	A108 1018 CS or A105 CS ⁸	A479 316 SS
3	Nozzle	Br. B16 ³	A479 316 SS	A479 316 SS
4	Guide	Br. B16 ³	A479 316 SS	A479 316 SS
5	Spindle	Br. B16 ³	A479 316 SS	A479 316 SS
6	Spring	316 SS or 17-7 PH SS	Note 7	316 SS, 17-7 PH SS, or 17-4 PH SS
7	Spring Washer	Br. B16	A108 12L14 CS ⁸	A479 316 SS
8	Seat Retainer Screw	316 SS ⁶ , 17-4 PH SS ⁴ or Brass ⁵	AST ⁵ , 17-4 PH SS ⁴ or 316 SS ⁶	17-4 PH SS ⁴ or 316 SS ^{5, 6}
9	Seat Retainer ⁵	Br. B16	A276 316 SS	SA 276 316 SS
10	Blowdown Adjustment Screw or Plug ⁶	Br. B16 or 316 SS ⁶	A108 12L14 CS ⁸ or 316 SS ⁶	316 SS
11	Pressure Adjustment Screw	Br. B16	A108 12L14 CS ⁸	A479 316 SS
12	Cap	Br. B16 ⁹	A108 12L14 CS ^{8, 9}	A479 316 SS ⁹
13	Drive Pin ¹⁰	316 SS	316 SS	316 SS
14	Seat	Refer to page 40	Refer to page 40	Refer to page 40
15	Blowdown Adj. Screw or Plug ⁶ Seal	Refer to page 40	Refer to page 40	Refer to page 40
16	Bushing Seal	Refer to page 40	Refer to page 40	Refer to page 40
17	Guide Seal ⁶	Refer to page 40	Refer to page 40	Refer to page 40
18	Spindle Seal ⁶	Refer to page 40	Refer to page 40	Refer to page 40
19	Stabilizing Ring ⁶	Refer to page 40	Refer to page 40	Refer to page 40
20	Lock Nut, Pressure Adjustment Screw	Br. B16	A108 12L14 ⁸ CS	A479 316 SS
21	Lock Nut, Blowdown Adjustment Screw ¹⁰	BRS	A307 CS ⁸	A194-8M SS

Notes

1. Other materials available on special order.
2. Materials may be furnished to meet NACE MR0175 for sour gas service. Materials are either heat treated or alternative materials are furnished to factory option to meet NACE.
3. 316 SS for Type 81P and Type 86.
4. Type 81 and Type 86.
5. Type 83.
6. Type 81P.
7. 316 SS, 17-7 PH SS, 17-4 PH SS or 1060-1075 CS (Aluminum coated) depending upon set pressure.
8. Zinc cobalt plated.
9. A582-303 for cap with lift lever option.
10. Not used on Type 81P.

Ordering – Types 81, 83, 86 and 81P Materials of Construction
 Orifice Sizes F to J

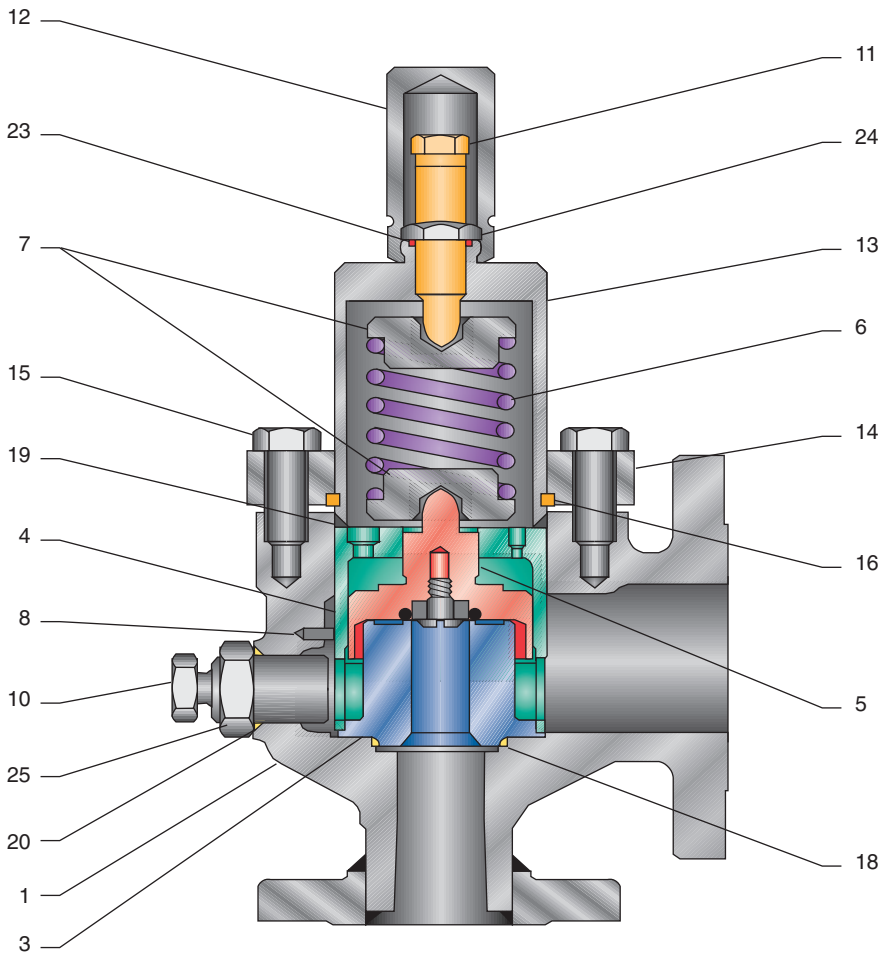

81P Seat (plastic)

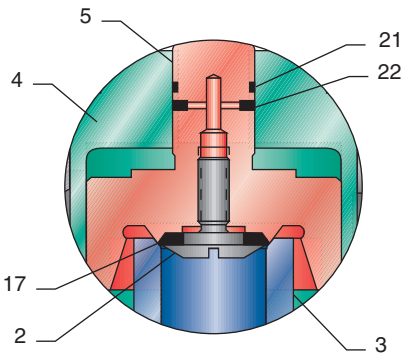

83 Seat (O-ring)

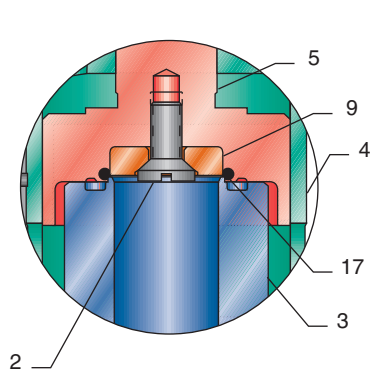

81 and 86 Seat (plastic)

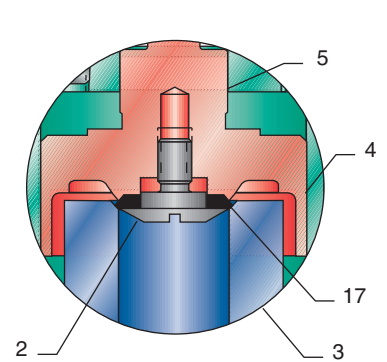

Ordering – Types 81, 83, 86 and 81P Materials of Construction

Standard Materials¹ - Types 81, 83, 86 and 81P for Orifice Sizes F to J

Item No.	Part Name	Brass	CS ²	SS ²
1	Body	SB62 BRS	SA216-WCB CS	SA351-CF8M SS
2	Seat Retainer Screw	17-4 PH SS or 316 SS ⁵	17-4 PH SS or AST ⁵	17-4 PH SS or 316 SS ⁵
3	Nozzle	A479 316 SS ³	A479 316 ³ SS	A479 316 SS ³
4	Guide	A479 316 SS	A479 316 SS	A479 316 SS
5	Spindle	A479 316 SS ³	A479 316 ³ SS	A479 316 SS ³
6	Spring	316 SS or 1060-1075 CS (Aluminum coated)	316 SS or 1060-1075 CS (Aluminum coated)	316 SS, 17-7 PH SS or 17-4 PH SS
7	Spring Washer	A479 316 SS	A108 12L14 CS	A479 316 SS
8	Drive Pin ⁷	316 SS	316 SS	316 SS
9	Seat Retainer ⁵	A479 316 SS	A479 316 SS	A479 316 SS
10	Blowdown Adj. Screw or Plug ⁶	A479 316 SS	A108 12L14 CS ⁴	A479 316 SS
11	Pressure Adjustment Screw	A479 316 SS	A108 1213/1215 CS ⁴	A479 316 SS
12	Cap	A479 316 SS	A108 12L14 CS ⁴	A479 316 SS
13	Spring Bonnet	A479 316 SS	A105 CS ⁴	A479 316 SS
14	Bonnet Flange	A240 316 SS	A516 70 CS ⁴	A240 316 SS
15	Bonnet Bolting	A193 B8M SS	A449/A325 ⁴	A193 B8M SS
16	Split Ring	A269 304 SS	A106 CS ⁴	A269 304 SS
17	Seat	Refer to page 40	Refer to page 40	Refer to page 40
18	Nozzle Seal	Refer to page 40	Refer to page 40	Refer to page 40
19	Bonnet Seal	Refer to page 40	Refer to page 40	Refer to page 40
20	Blowdown Adj. Screw or Plug ⁶ Seal	Refer to page 40	Refer to page 40	Refer to page 40
21	Spindle Seal ⁶	Refer to page 40	Refer to page 40	Refer to page 40
22	Stabilizing Ring ⁶	Refer to page 40	Refer to page 40	Refer to page 40
23	Pressure Seal	Refer to page 40	Refer to page 40	Refer to page 40
24	Lock Nut, Pressure Adjustment Screw	A479 316 SS	A108 12L14 CS ⁴	A479 316 SS
25	Lock Nut, Blowdown Adjustment Screw	A194 B8M SS	A307 Steel ⁴	A194 B8M SS

Notes

1. Other materials available on special order.
2. Materials may be furnished to meet NACE MR0175 for sour gas service. Materials are either heat treated or alternative materials are furnished to factory option to meet NACE.
3. 17-4 PH SS used for Type 81 and Type 86.
4. Zinc cobalt plated.
5. Type 83.
6. Type 81P.
7. Not used on Type 81P.

Ordering – Materials of Construction

Standard Seat and Seal Options

Part Name	Applicable Orifice Sizes	Orifice Designation, Seat Option and Seal Materials	
		Model 81 -4, -6, -8, F, G, H & J	Model 86 -4, -8, G & J
Seat	All	Teflon ^{®1,2} – PCTFE ^{1,2} – Vespel ^{1,2}	Teflon ^{®1,2} – PEEK ^{1,2}
Bushing Seal	-4 to -8	Glass Filled Teflon ^{®1,2}	Glass Filled Teflon ^{®1,2}
Nozzle Seal	F to J	Teflon ^{®1,2}	Teflon ^{®1,2}
Bonnet Seal	F to J	Glass Filled Teflon ^{®1,2}	Glass Filled Teflon ^{®1,2}
Blowdown Adj. Screw Seal	All	Teflon ^{®1,2}	Teflon ^{®1,2}
Pressure Seal	F to J	Teflon ^{®1,2}	Teflon ^{®1,2}

Notes

1. Factory standard seat and seal materials. Other seat and seal materials available on special order.
2. Factory standard seat and seal material: NACE option.
3. G Orifice set pressure: 721 psig and above [49.7 barg and above].
J Orifice set pressure: 100 psig and above [6.9 barg and above].

Standard Seat and Seal Options

Part Name	Applicable Orifice Sizes	Orifice Designation, Seat Option and Seal Materials	
		Model 83 -4, -6, -8, F, G, H & J	Model 81P -4, -8, G & J
Seat	All	BUNA-N ¹ – EPR – Viton ^{®2}	Teflon ^{®1,2} – PCTFE ^{1,2}
Bushing Seal	-4 to -8	BUNA-N ¹ – EPR – Viton ^{®2}	BUNA-N ¹ – EPR – Viton ^{®2}
Nozzle Seal	F to J	BUNA-N ¹ – EPR – Viton ^{®2}	BUNA-N ¹ – EPR – Viton ^{®2}
Guide Seal	-4 to -8	—	BUNA-N ¹ – EPR – Viton ^{®2}
Bonnet Seal	F to J	BUNA-N ¹ – EPR – Viton ^{®2}	BUNA-N ¹ – EPR – Viton ^{®2}
Stabilizing Ring	All	—	BUNA-N ¹ – EPR – Viton ^{®2}
Drag Ring	G and J	—	Cast Monomer ³
Spindle Seal	All	—	BUNA-N ¹ – EPR – Viton ^{®2}
Blowdown Adjustment Screw or Plug Seal	All	Teflon ^{®1,2}	Teflon ^{®1,2}
Pressure Seal	F to J	Teflon ^{®1,2}	—

Ordering – Additional Information

After selecting valve type, orifice and materials of construction, the following information might be required, depending on the type of valve and other requirements:

Flanged Valves

If ordering a flanged valve, separately specify pressure class, facing, and finish for both the inlet and outlet. To ensure best delivery, please follow the specified flange practices as listed in the ANSI standards. When the model number describes flanged connections, the flange dimensions and finish will meet the ANSI standards. Any deviation from the standard must be clearly specified.

Service

Provide the specific name of the fluid and state to be relieved. When small amounts (including trace amounts) of other fluids are present, indicate their name and concentration. This is important for both the selection of metallic components as well as the soft seats and seals. Note that certain valve models are recommended for gas, liquid, or steam service.

Temperature

Furnish the normal operating temperature and the relieving temperature. When the ambient temperature varies significantly from normal conditions, such as arctic environments, furnish that temperature as well. It is more important to select the seat and seal materials on the basis of the continuous service temperature. The pressure containing parts of the pressure relief valve should consider the three temperature conditions of continuous service, relieving, and ambient.

Set Pressure

Specify set pressure in psig or in other commonly accepted units. If set pressure is given in absolute terms, 14.7 psig [1.01 barg] pressure will be deducted to establish the factory setting. This gauge pressure value will be applied to the valve name plate.

Special Requirements

Please specify the details of any special procedures you require during valve manufacturing. These might include unlisted accessories, special quality assurance, material traceability, non-standard plating and surface finishes, non-destructive test requirements, etc. Include required levels of inspection and the parties or organizations who will perform the inspections, if any. *Special requirements can impact price and delivery.*

Valve Tagging

If paper tags are requested at the time the valve is ordered, they will be furnished at no additional cost. Other types of tagging are offered at additional cost. If you would like metallic tags, please identify the specific tag material, and tag numbers when you place your order.

Documentation

Data submittals are not furnished for ordered products unless specified. Certain standard drawings, test reports, and certifications are available upon request.

Packing for Shipment

All products are packed for normal domestic shipment from point of assembly or stocking. Special packaging requirements, such as export boxing, are available.

Ordering Information – Model Number

81P

S1

N

S

8

A

Valve Type

- 81 – Plastic Seated, Gas Service
- 83 – O-ring Seated, Gas Service
- 86 – Plastic Seated, Steam Service
- 81P – Plastic Seated, Liquid Service
- 61 – Plastic Seated, Gas Service
- 63 – O-ring Seated, Gas Service

Body Material

- S – 316 SS
- S1 – CS with 316 SS Trim
- B – Brass

NACE

- N – Materials to meet NACE MR0175 (2002 Edition)
- Blank – Standard (without NACE)

Port Type

- F – Threaded FNPT Inlet and Outlet
- M – Threaded MNPT Inlet and Threaded FNPT Outlet
- J – Threaded MS-33649 Inlet and Outlet (Military Standard)
- S – Standard Flanged Inlet and Outlet
- W – Weldneck Flanged Inlet and Outlet
- U – Weldneck Flanged Inlet and Standard Cast Flanged Outlet
- T – Weldneck Flanged Inlet and FNPT Outlet
- X – Slip-on Flanged Inlet and FNPT Outlet
- Y – Slip-on Flanged Inlet and Weldneck Flanged Outlet
- Blank – Special

Inlet Size, 1/8"

- 4 – 1/2" [15 mm]
- 6 – 3/4" [18 mm]
- 8 – 1" [25 mm]
- 12 – 1 1/2" [40 mm]
- 16 – 2" [50 mm]

Inlet Flange Rating

- A – 150#
- B – 300#
- C – 600#
- D – 900#
- E – 1500#
- F – 2500#
- Blank – Not Applicable (Threaded Inlet)

Ordering Information – Model Number

16

A

-8

L

Lift Lever

- L – Packed Lift Lever
- Blank – Standard, without Lift Lever

Orifice

- 4 – 0.049 in² [0.32 cm²]
- 5 – 0.077 in² [0.50 cm²] (Type 63B Only)
- 6 – 0.110 in² [0.71 cm²] (D)
- 7 – 0.150 in² [0.968 cm²] (Type 63B Only)
- 8 – 0.196 in² [1.27 cm²] (Types 81, 83, 86 and 81P to 4000 psig [276 barg])
- E – 0.196 in² [1.27 cm²] (Types 81 and 81P set over 4000 psig [276 barg])
- F – 0.307 in² [1.98 cm²]
- G – 0.503 in² [3.25 cm²]
- H – 0.785 in² [5.07 cm²]
- J – 1.287 in² [8.30 cm²]

Outlet Flange Rating

- A – 150#
- B – 300#
- C – 600#
- D – 900#
- E – 1500#
- F – 2500#
- Blank – Not Applicable (Threaded Outlet)

Outlet Size, 1/8"

- 6 – 3/4" [18 mm]
- 8 – 1" [25 mm]
- 12 – 1 1/2" [40 mm]
- 16 – 2" [50 mm]
- 24 – 3" [80 mm]

Example:

81PS1NS8A16A – 8L

81P liquid relief valve, A216 WCB CS body, 316 SS trim, valve built to NACE MR0175, 1" [25 mm] - 150# RF x 2" [50 mm] - 150# RF connections, 0.196 in² [1.27 cm²] orifice, packed lift lever.

Soft Goods Code

The code show below is stamped on the nameplate of the valve for easy identification in the field.

Seat Material

- B – BUNA-N
- V – Viton®
- E – Ethylene Propylene
- R – BUNA-N, CO₂ Service (Seat Material Only) Type 83: -4, -6, -8
Orifice set pressures 720 psig [49.6 barg] and up
- A – Aflas
- Z – Kalrez®
- T – Teflon®
- K – PCTFE
- W – Vespel
- P – PEEK

Seal Material

- B – BUNA-N
- V – Viton®
- E – Ethylene Propylene
- A – Aflas
- Z – Kalrez®
- T – Teflon®

Accessories and Options

Packed Lift Lever

The packed lift lever for all Series 80 valves allows the valve to be manually actuated at system operating pressures at least 75% of set pressure, with no process venting through the lever mechanism.

Paragraph UG. 136(a) of the ASME Boiler and Pressure Vessel Code Section VIII, Division 1, requires a lifting device for pressure relief valves on air, steam, and hot water above 140°F [60°C].

Test Gags

The test gag can be provided to prevent valve opening during system hydrotests.

NACE Option

Essential option for sour gas service

This is a material option to meet the stress corrosion problems associated with sour gas service (hydrogen sulfide). The wetted parts of the valve will meet the requirements of NACE MR0175 (2002 Edition). Although the materials will vary from valve to valve, due to size and pressure rating, they meet NACE requirements in all instances.



Availability of Accessories and Options

Accessory/Option	Valve Type					
	81	83	86	81P	61	63B
Packed Lift Lever	Optional	Optional	Standard	Optional	Not Available	Not Available
NACE Trim	Optional	Optional	Optional	Optional	Not Available	Not Available
Test Gag	Optional	Optional	Optional	Optional	Not Available	Not Available

Appendix

Valve Operation – Types 81, 83, and 86

Types 81, 83, and 86 safety valves operate as described below.

1. System pressure is applied at the inlet to the seat area and exerts a force on the spindle. This upward force is counteracted by the downward force of the spring (see Figure 1, page 47).

While the system pressure is below set pressure, the pressure in the spring chamber, the inner chamber, and the outlet is atmospheric (or uniformly exposed to the current superimposed back pressure, if any) (see Figure 2, page 47).

2. A secondary orifice, consisting of two or more holes in the guide, permits gas discharge to the spring chamber when the valve opens.

This orifice also functions to develop a back pressure in the spring chamber after valve actuation. If the system pressure increases to the point where the total upward force overcomes the spring force, the valve opens (see Figure 3, page 47).

3. At set pressure, the initial flow across the seat is exposed to the additional area of the spindle skirt, which generates additional lifting forces. At this opening instant, the pressure in the inner chamber is greater than the pressure in the spring chamber. This is due to the restricted annular area between the spindle and the guide. This increased force rapidly accelerates the spindle to its full open position (see Figure 4, page 47).

4. After the spindle has lifted, a developed back pressure will be present in the spring chamber. This is due to the pressure drop across the secondary orifice. This pressure then acts down against the area of the spindle, as a supplemental force to assist the spring in closing the spindle (see Figure 4, page 47).

5. This pressure in turn can be adjusted externally with a threaded bolt, which partially restricts one of the guide holes. This adjustment varies the amount of developed back pressure in the spring chamber (see Figure 4, page 47) and controls blowdown, independently of set pressure.

Complete restriction of the flow through one of these guide holes by the blowdown adjustment will not affect capacity since the back pressure will never exceed 50 percent of the inlet pressure (see Figure 4, page 47).

6. At some point, the inlet (system) pressure will drop to a level where the combined spring force and the developed back pressure on the spindle top will overcome the lifting force on the seat area and cause the spindle to start down. As soon as this happens, the pressure in the inner chamber is instantaneously reduced a small amount. This increases the unbalance in a downward direction, and the spindle accelerates downward, causing the valve to close with a snap action (see Figure 5, page 47).
7. After valve reseating, residual pressure in the spring chamber immediately dissipates to the valve outlet, back to atmospheric pressure (or the current value of superimposed back pressure). The safety relief valve is again back to its initial status prior to opening (see Figure 6, page 47).

Appendix
Valve Operation – Types 81, 83, and 86

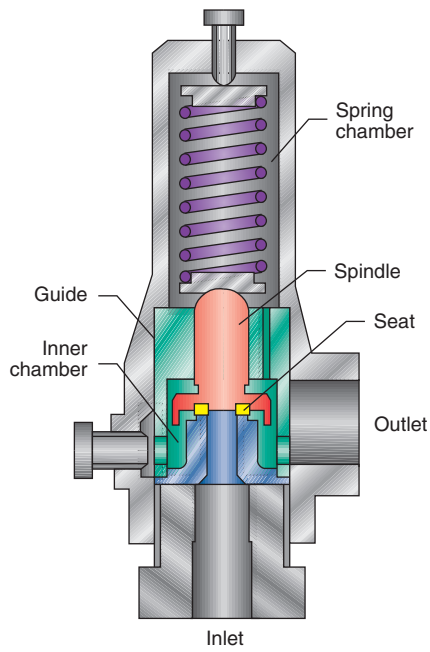

Figure 1

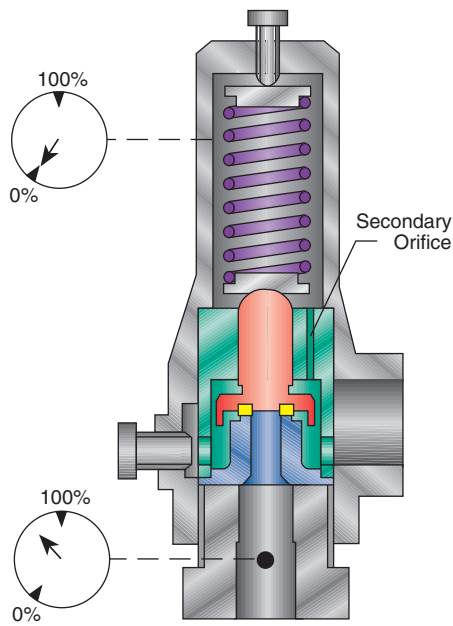

Figure 2

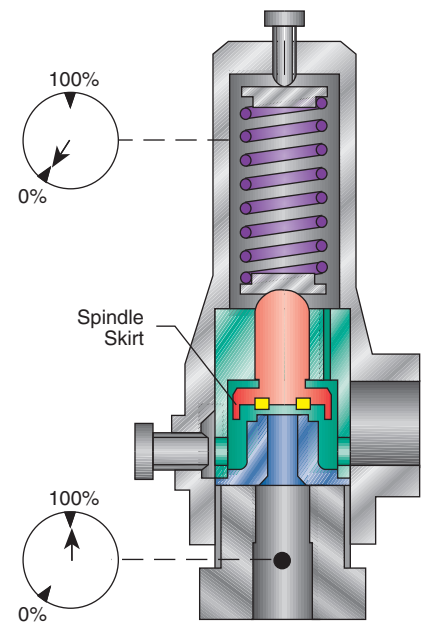

Figure 3

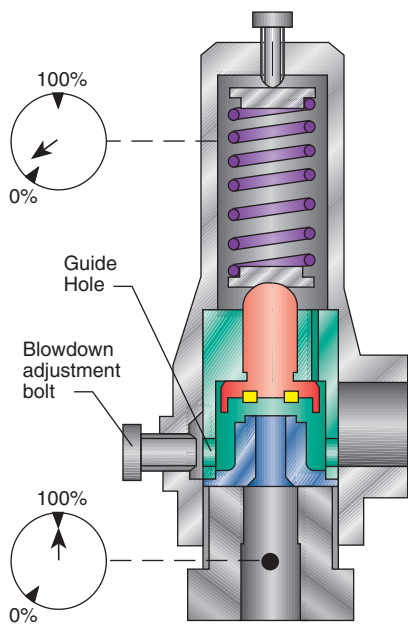

Figure 4

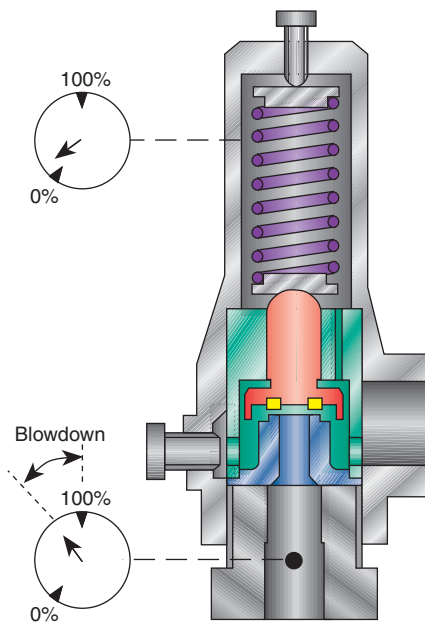

Figure 5

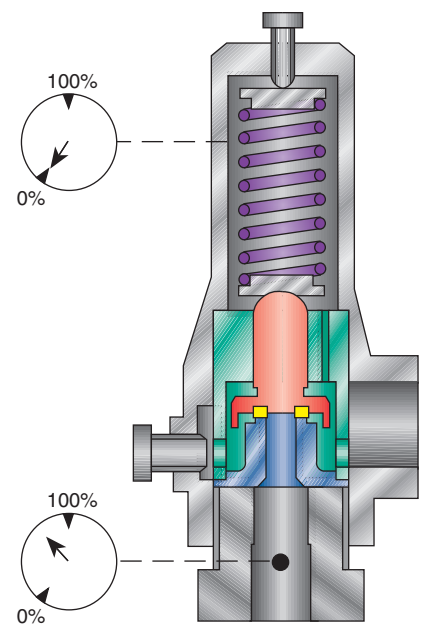

Figure 6

Appendix

Valve Operation – Types 81P, 61 and 63B

Type 81P relief valves operate as described below.

1. With system pressure below set pressure, the valve will be completely leak-free, through the use of a replaceable soft seat (see Figure 7, page 49).
2. When the system pressure reaches set pressure, the valve will begin to open with a small steady flow of liquid (see Figure 8, page 49).

The huddling chamber of the Type 81P is similar to that of the Types 81, 83 and 86, and functions to develop full lift by 10 percent overpressure. Some conventional liquid safety relief valves still require 25 percent overpressure to achieve full opening and to reach their rated capacity.

3. After initial flow at set pressure, the Type 81P valve will smoothly and progressively open with system pressure increase. The valve will reach full lift and rated capacity by 10 percent overpressure (see Figure 9, page 49).
4. When the full rated capacity is required, the Type 81P will exhibit a blowdown of approximately 20 percent (see Figure 10, page 49). When full relieving capacity is not required, the magnitude of blowdown will become progressively smaller. If the system pressure does not significantly rise after reaching set pressure, the valve will reclose at or near the set pressure, similar to the operation of a modulating pilot operated safety relief valve.

Specifically, the Type 61 and 63B safety valves operate identically and as described below.

1. System pressure is applied at the inlet to the seat area and exerts a force on the spindle.
2. This upward force is counteracted by the larger, downward force of the spring, which, along with the soft seat, ensures that the valve is bubble-tight.
3. When system pressure increases to the point where the total upward force overcomes the spring force, the valve opens.
4. When the valve set pressure has been reached, the spindle lifts slightly, and the system pressure transfers its effect from the seat area to the larger spindle skirt area.
5. This area change, along with the spindle skirt redirecting the flow downward, generates additional lifting forces and snaps the spindle into full lift by 10 percent overpressure.
6. At some point, the system pressure will drop to a level where the downward spring force can overcome the reduced spindle lifting force, and the valve will reseal bubble-tight.

Appendix

Valve Operation – Types 81P

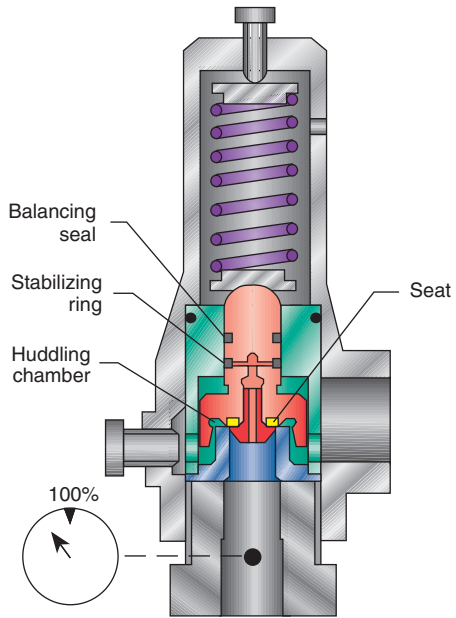

Figure 7

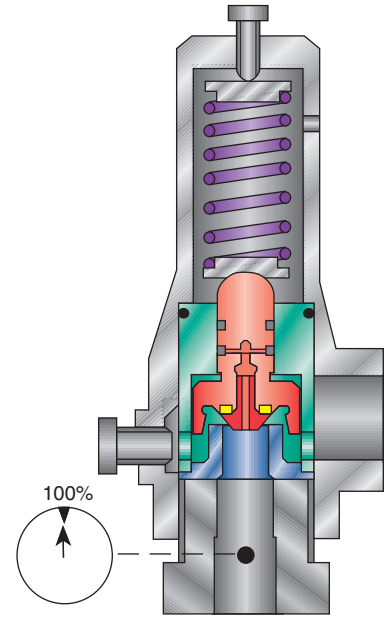

Figure 8

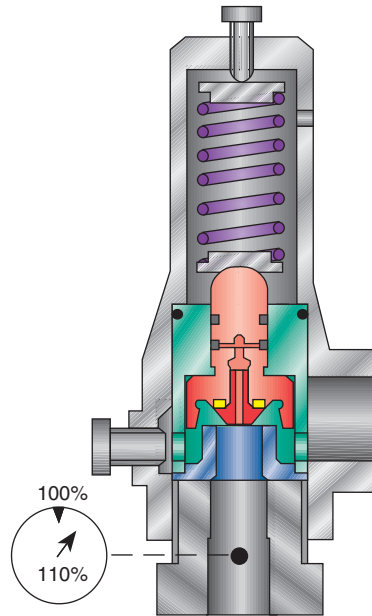

Figure 9

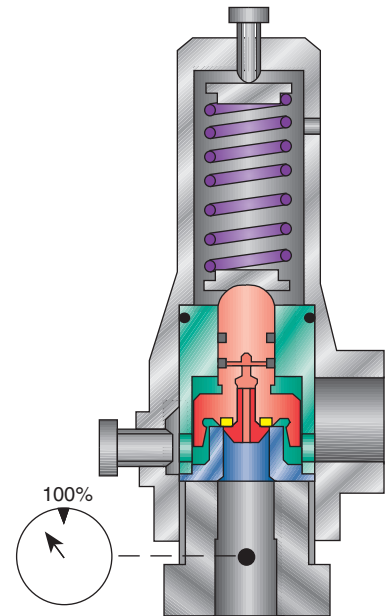

Figure 10

Appendix

Types 81 and 83 Capacities

Types 81 and 83 Capacities¹ - SCFM [Nm³/hr] Air - National Board Certified

Set Pressure psig [barg]	-4		-6		-8		F		G		H		J	
	0.049 in ² [0.32 cm ²]		0.110 in ² [0.71 cm ²]		0.196 in ² [1.26 cm ²]		0.307 in ² [1.98 cm ²]		0.503 in ² [3.25 cm ²]		0.785 in ² [5.07 cm ²]		1.287 in ² [8.30 cm ²]	
20 [1.38]	28 [45.0]	62 [99.7]	111 [178.5]	173 [278.2]	284 [456.7]	443 [712.3]	726 [1167.4]							
40 [2.76]	43 [69.1]	97 [156.0]	172 [276.6]	270 [434.2]	442 [710.7]	689 [1107.9]	1130 [1817.0]							
60 [4.14]	59 [94.9]	133 [213.9]	237 [381.1]	371 [596.6]	607 [976.1]	948 [1524.4]	1554 [2492.6]							
80 [5.52]	75 [120.6]	169 [271.8]	301 [484.0]	472 [759.0]	773 [1243.0]	206 [1939.2]	1997 [3211.2]							
100 [6.9]	91 [146.3]	205 [329.6]	366 [588.5]	573 [921.4]	938 [1508.3]	1464 [2354.1]	2401 [3860.8]							
120 [8.3]	108 [173.7]	241 [387.5]	430 [691.4]	674 [1083.8]	1104 [1775.2]	1723 [2770.6]	2824 [4541.0]							
140 [9.7]	124 [199.4]	278 [447.0]	495 [796.0]	775 [1246.2]	1269 [2040.6]	1981 [3185.5]	3248 [5222.8]							
160 [11.0]	140 [225.1]	314 [504.9]	559 [898.9]	876 [1408.6]	1435 [2307.5]	2239 [3600.3]	3671 [5903.0]							
180 [12.4]	156 [250.9]	350 [562.8]	624 [1003.4]	977 [1571.0]	1600 [2572.8]	2498 [4016.8]	4095 [6584.8]							
200 [13.8]	172 [276.6]	386 [620.7]	688 [1106.3]	1078 [1733.4]	1766 [2839.7]	2756 [4431.7]	4518 [7264.9]							
240 [16.6]	204 [328.0]	459 [738.1]	817 [1313.7]	1280 [2058.2]	2097 [3372.0]	3273 [5263.0]	5365 [8626.9]							
280 [19.3]	237 [381.1]	531 [853.9]	946 [1521.2]	1482 [2383.1]	2428 [3904.2]	3789 [6092.7]	6212 [9988.9]							
300 [20.7]	253 [406.8]	567 [911.7]	1011 [1625.7]	1583 [2545.5]	2594 [4171.2]	4048 [6509.2]	6636 [10,670.7]							
340 [23.4]	285 [458.3]	640 [1029.1]	1140 [1833.1]	1785 [2870.3]	2925 [4703.4]	4564 [7338.9]	7483 [12,032.7]							
380 [26.2]	317 [509.7]	712 [1144.9]	1269 [2040.6]	1987 [3195.1]	3256 [5235.7]	5081 [8170.2]	8330 [13,394.6]							
400 [27.6]	333 [535.5]	748 [1202.8]	1333 [2143.5]	2088 [3357.5]	3421 [5501.0]	5339 [8585.1]	8754 [14,076.4]							
440 [30.3]	366 [588.5]	821 [1320.2]	1462 [2350.9]	2290 [3682.3]	3752 [6033.2]	5856 [9416.5]	9601 [15,438.4]							
480 [33.1]	398 [640.0]	893 [1435.9]	1591 [2558.3]	2492 [4007.1]	4083 [6565.5]	6373 [10,247.8]	10,448 [16,800.4]							
500 [34.5]	414 [665.7]	929 [1493.8]	1656 [2662.9]	2593 [4169.5]	4249 [6832.4]	6631 [10,662.6]	10,871 [17,480.6]							
600 [41.4]	495 [796.0]	1110 [1784.9]	1978 [3180.6]	3098 [4981.6]	5076 [8162.2]	7922 [12,738.6]	12,989 [20,886.3]							
700 [48.3]	575 [924.6]	1291 [2075.9]	2301 [3700.0]	3603 [5793.6]	5904 [9493.6]	9214 [14,816.1]	15,106 [24,290.5]							
800 [55.2]	656 [1054.9]	1472 [2367.0]	2623 [4217.8]	4109 [6607.3]	6732 [10,825.1]	10,506 [16,893.7]	17,224 [27,696.2]							
900 [62.1]	736 [1183.5]	1653 [2658.0]	2946 [4737.2]	4614 [7419.3]	7559 [12,154.9]	11,797 [18,969.6]	19,342 [31,101.9]							
1000 [69.0]	817 [1313.7]	1834 [2949.0]	3268 [5254.9]	5119 [8231.4]	8387 [13,486.3]	13,089 [21,047.1]	21,459 [34,506.0]							
1500 [103.4]	1220 [1961.8]	2739 [4404.3]	4881 [7848.7]	7645 [12,293.16]	12,525 [20,140.2]	19,547 [31,431.6]	32,048 [51,533.2]							
2000 [137.9]	1623 [2609.8]	3644 [5859.6]	6493 [10,440.7]	10,170 [16,353.4]	16,663 [26,774.1]	26,006 [41,817.7]	—	—						
2500 [172.4]	2026 [3257.8]	4549 [7314.8]	8106 [13,034.5]	12,696 [20,415.2]	20,802 [33,449.6]	32,464 [52,202.1]	—	—						
3000 [206.9]	2430 [3907.4]	5454 [8770.0]	9718 [15,626.5]	15,222 [24,476.98]	—	—	—	—						
4000 [275.8]	3236 [5203.5]	7264 [11,680.5]	12,943 [20,812.3]	20,273 [32,599.0]	—	—	—	—						
5000 [344.8]	4042 [6499.5]	9074 [14,591.0]	16,168 [25,998.1]	—	—	—	—	—						
6000 [413.7]	4848 [7795.6]	10,884 [17,501.5]	19,393 [31,183.9]	—	—	—	—	—						
7000 [482.7]	5655 [9093.2]	12,694 [20,412.0]	—	—	—	—	—	—						
8000 [551.6]	6461 [10,389.3]	14,504 [23,322.4]	—	—	—	—	—	—						
9000 [620.6]	7267 [11,685.3]	16,314 [26,232.9]	—	—	—	—	—	—						
10,000 [689.5]	8073 [12,981.4]	—	—	—	—	—	—	—						

Notes

1. 60°F [16°C], Z = 1.00; 10% overpressure or 3 psig [0.21 barg] (whichever is greater).

2. Metric conversions:
barg = psig x 0.06895
cm² = in² x 6.4516

Nm³/hr = SCFM x 1.608
°C = [°F - 32] x 0.5556

Appendix
Types 81 and 83 Capacities

Types 81 and 83 Capacities¹ - SCFM [Nm³/hr] Natural Gas - Molecular Weight = 17.4

Set Pressure psig [barg]	-4		-6		-8		F		G		H		J	
	0.049 in ² [0.32 cm ²]		0.110 in ² [0.71 cm ²]		0.196 in ² [1.26 cm ²]		0.307 in ² [1.98 cm ²]		0.503 in ² [3.25 cm ²]		0.785 in ² [5.07 cm ²]		1.287 in ² [8.30 cm ²]	
20 [1.38]	34 [54.7]	75 [120.6]	134 [215.5]	210 [337.7]	344 [553.2]	537 [863.5]	881 [1416.7]							
40 [2.76]	54 [86.8]	120 [193.0]	215 [345.7]	336 [540.3]	551 [886.0]	859 [1381.3]	1409 [2265.7]							
60 [4.14]	74 [119.0]	166 [266.9]	295 [474.4]	462 [742.9]	757 [1217.3]	1181 [1899.0]	1937 [3114.7]							
80 [5.52]	94 [151.2]	211 [339.3]	375 [603.0]	588 [945.5]	963 [1548.5]	1504 [2418.4]	2465 [3963.7]							
100 [6.9]	114 [183.3]	256 [411.6]	456 [733.2]	714 [1148.1]	1170 [1881.4]	1826 [2936.2]	2993 [4812.7]							
120 [8.3]	134 [215.5]	301 [484.0]	536 [861.9]	840 [1350.7]	1376 [2212.6]	2148 [3454.0]	3521 [5661.8]							
140 [9.7]	154 [247.6]	346 [556.4]	617 [992.2]	966 [1553.3]	1583 [2545.5]	2470 [3971.8]	4049 [6510.8]							
160 [11.0]	174 [279.8]	391 [628.7]	697 [1120.8]	1092 [1755.9]	1789 [2876.7]	2792 [4489.5]	4577 [7359.8]							
180 [12.4]	194 [312.0]	436 [701.1]	778 [1251.0]	1218 [1958.5]	1995 [3208.0]	3114 [5007.3]	5105 [8208.8]							
200 [13.8]	214 [344.1]	481 [773.5]	858 [1379.7]	1344 [2161.2]	2202 [3540.8]	3436 [5525.1]	5634 [9059.5]							
240 [16.6]	255 [410.0]	572 [919.8]	1019 [1638.6]	1596 [2566.4]	2615 [4197.1]	4080 [6560.6]	6690 [10,757.5]							
280 [19.3]	295 [474.4]	662 [1064.5]	1180 [1897.4]	1848 [2971.6]	3027 [4867.4]	4725 [7597.8]	7746 [12,455.6]							
300 [20.7]	315 [506.5]	707 [1136.9]	1260 [2026.1]	1974 [3174.2]	3234 [5200.3]	5047 [8115.6]	8274 [13,304.6]							
340 [23.4]	355 [570.8]	797 [1281.6]	1421 [2285.0]	2226 [3579.4]	3646 [5862.8]	5691 [9151.1]	9330 [15,002.6]							
380 [26.2]	395 [635.2]	888 [1427.9]	1582 [2543.9]	2478 [3984.6]	4059 [6526.9]	6335 [10,186.7]	10,386 [16,700.7]							
400 [27.6]	416 [668.9]	933 [1500.3]	1662 [2672.5]	2603 [4185.6]	4266 [6859.7]	6657 [10,704.5]	10,914 [17,549.7]							
440 [30.3]	456 [733.2]	1023 [1645.0]	1823 [2931.4]	2855 [4590.8]	4678 [7522.2]	7301 [11,740.0]	11,970 [19,247.8]							
480 [33.1]	496 [797.6]	1113 [1789.7]	1984 [3190.3]	3107 [4996.1]	5091 [8186.3]	7945 [12,775.6]	13,027 [20,947.4]							
500 [34.5]	516 [892.7]	1159 [1836.7]	2064 [3318.9]	3233 [5198.7]	5298 [8519.2]	8268 [13,294.9]	13,555 [21,796.4]							
600 [41.4]	617 [992.1]	1384 [2225.5]	2466 [3965.3]	3863 [6211.7]	6329 [10,177.0]	9878 [15,883.8]	16,195 [26,041.6]							
700 [48.3]	717 [1152.9]	1610 [2588.9]	2868 [4611.7]	4493 [7224.7]	7361 [11,836.5]	11,488 [18,408.4]	18,835 [30,287.0]							
800 [55.2]	818 [1315.3]	1836 [2952.3]	3271 [5259.8]	5123 [8237.8]	8393 [13,495.9]	13,099 [21,063.2]	21,476 [34,533.4]							
900 [62.1]	918 [1476.1]	2061 [3314.1]	3673 [5906.2]	5753 [9250.8]	9425 [15,155.4]	14,709 [23,652.1]	24,116 [38,779.0]							
1000 [69.0]	1019 [1638.6]	2287 [3677.5]	4075 [6552.6]	6382 [10,262.3]	10,457 [16,814.9]	16,320 [26,242.6]	26,756 [43,023.6]							
1500 [103.4]	1521 [2445.8]	3415 [5491.3]	6085 [9784.7]	9532 [15,327.5]	15,617 [25,112.1]	24,372 [39,190.2]	39,958 [64,252.5]							
2000 [137.9]	2024 [3254.6]	4544 [7306.8]	8096 [13,018.4]	12,681 [20,391.0]	20,776 [33,407.8]	32,425 [52,139.4]	—	—						
2500 [172.4]	2527 [4063.4]	5672 [9120.6]	10,106 [16,250.5]	15,830 [25,454.6]	25,936 [41,705.1]	40,477 [65,087.1]	—	—						
3000 [206.9]	3029 [4870.6]	6800 [10,934.4]	12,117 [19,484.1]	18,979 [30,518.2]	—	—	—	—						
4000 [275.8]	4034 [6486.7]	9057 [14,563.7]	16,138 [25,949.9]	25,277 [40,565.0]	—	—	—	—						
5000 [344.8]	5040 [8104.3]	11,314 [18,192.9]	0,159 [32,415.7]	—	—	—	—	—						
6000 [413.7]	6045 [9720.4]	13,570 [21,820.6]	24,180 [38,881.4]	—	—	—	—	—						
7000 [482.7]	7050 [11,336.4]	15,827 [25,449.8]	—	—	—	—	—	—						
8000 [551.6]	8056 [12,954.0]	18,084 [29,079.1]	—	—	—	—	—	—						
9000 [620.6]	9061 [14,570.0]	20,431 [32,853.1]	—	—	—	—	—	—						
10,000 [689.5]	10,066 [10,750.5]	—	—	—	—	—	—	—						

Notes

1. 60°F [16°C], Z = 1.00; 10% overpressure or 3 psig [0.21 barg] (whichever is greater).

2. Metric conversions:
barg = psig x 0.06895
cm² = in² x 6.4516

Nm³/hr = SCFM x 1.608
°C = [°F - 32] x 0.5556

Appendix

Type 86 Capacities

Type 86 Capacities¹ - lb/hr [kg/hr] Saturated Steam - National Board Certified

Set Pressure		-4		-8		G		J	
psig	[barg]	0.049 in ² [0.32 cm ²]		0.196 in ² [1.27 cm ²]		0.503 in ² [3.25 cm ²]		1.287 in ² [8.30 cm ²]	
50	[3.45]	144	[65.3]	574	[260]	1473	[668]	3770	[1710]
60	[4.14]	166	[75.3]	665	[302]	1706	[774]	4365	[1980]
80	[5.52]	211	[95.7]	846	[384]	2171	[985]	5555	[2520]
100	[6.9]	257	[116.6]	1027	[466]	2636	[1196]	6744	[3059]
120	[8.3]	302	[137.0]	1208	[548]	3101	[1407]	7934	[3599]
140	[9.7]	347	[157.4]	1390	[631]	3566	[1618]	9124	[4139]
160	[11.0]	393	[178.3]	1571	[713]	4031	[1829]	10,314	[4678]
180	[12.4]	438	[198.7]	1752	[795]	4496	[2040]	1,504	[5218]
200	[13.8]	483	[219.1]	1933	[877]	4961	[2250]	12,694	[5758]
220	[15.2]	529	[240.0]	2114	[959]	5426	[2461]	13,884	[6298]
240	[16.6]	574	[260.4]	2296	[1042]	5891	[2672]	15,073	[6837]
260	[17.9]	619	[280.8]	2477	[1124]	6356	[2883]	16,263	[7377]
280	[19.3]	664	[301.2]	2658	[1206]	6821	[3094]	17,453	[7917]
300	[20.7]	710	[322.1]	2839	[1288]	7286	[3305]	18,643	[8457]
320	[22.1]	755	[342.5]	3020	[1370]	7751	[3516]	19,833	[8996]
340	[23.4]	800	[362.9]	3202	[1452]	8216	[3727]	21,023	[9536]
360	[24.8]	846	[383.7]	3383	[1535]	8681	[3938]	22,213	[10,076]
380	[26.2]	891	[404.2]	3564	[1617]	9146	[4149]	23,403	[10,617]
400	[27.6]	936	[424.6]	3745	[1699]	9611	[4360]	24,592	[11,155]
420	[29.0]	982	[445.4]	3926	[1781]	10,077	[4571]	25,782	[11,695]
440	[30.3]	1027	[456.9]	4108	[1863]	10,542	[4782]	26,972	[12,235]
460	[31.7]	1072	[486.3]	4289	[1946]	11,007	[4993]	28,162	[12,774]
480	[33.1]	1118	[507.1]	4470	[2028]	11,472	[5204]	29,352	[13,314]
500	[34.5]	1163	[527.5]	4651	[2110]	11,937	[5415]	30,542	[13,854]
520	[35.9]	1208	[547.9]	4832	[2192]	12,402	[5626]	31,732	[14,394]
540	[37.2]	1253	[568.4]	5014	[2274]	12,867	[5837]	32,921	[14,933]
560	[38.6]	1299	[589.2]	5195	[2357]	13,332	[6047]	34,111	[15,473]
580	[40.0]	1344	[609.6]	5376	[2439]	13,797	[6258]	35,301	[16,013]
600	[41.4]	1389	[630.1]	5557	[2521]	14,262	[6469]	36,491	[12,016]
620	[42.7]	1435	[650.9]	5739	[2603]	14,727	[6680]	37,681	[17,092]
640	[44.2]	1480	[671.3]	5920	[2685]	15,192	[6891]	38,871	[17,632]
660	[45.5]	1525	[691.7]	6101	[2767]	15,657	[7102]	40,061	[18,172]
680	[46.9]	1571	[712.6]	6282	[2850]	16,122	[7313]	41,251	[18,712]
700	[48.3]	1616	[733.0]	6463	[2932]	16,587	[7524]	42,440	[19,251]
720	[49.6]	1661	[753.4]	6645	[3014]	7,052	[7735]	43,630	[19,791]

Notes

1. Saturation temperature - 10% overpressure.
2. Metric conversions:
 barg = psig x 0.06895
 cm² = in² x 6.4516
 kg/hr = lb/hr x 0.4536
 °C = [°F - 32] x 0.5556

Appendix
Type 81P Capacities

Type 81P Capacities¹ GPM [m³/hr] Water - National Board Certified

Set Pressure psig [barg]		-4 0.049 in ² [0.32 cm ²]		-8 0.196 in ² [1.27 cm ²]		G 0.503 in ² [3.25 cm ²]		J 1.287 in ² [8.30 cm ²]	
50	[3.45]	10	[2.3]	40	[9.1]	102	[23.2]	261	[59.3]
100	[6.9]	14	[3.2]	56	[12.7]	144	[32.7]	369	[83.8]
150	[10.3]	17	[3.9]	69	[15.7]	177	[40.2]	452	[102.6]
200	[13.8]	20	[4.5]	80	[18.2]	204	[46.3]	522	[118.5]
250	[17.2]	22	[5.0]	89	[20.2]	228	[51.8]	584	[132.6]
300	[20.7]	24	[5.5]	97	[22.0]	250	[56.8]	640	[145.3]
350	[24.1]	26	[5.9]	105	[23.9]	270	[61.3]	691	[156.9]
400	[27.6]	28	[6.4]	112	[25.4]	289	[65.6]	739	[167.8]
450	[31.0]	30	[6.8]	119	[27.0]	306	[69.5]	783	[177.8]
500	[34.5]	31	[7.0]	126	[28.6]	323	[73.4]	826	[187.6]
600	[41.4]	34	[7.7]	138	[31.3]	354	[80.4]	905	[205.5]
700	[48.3]	37	[8.4]	149	[33.8]	382	[86.8]	977	[221.9]
800	[55.1]	40	[9.1]	159	[36.1]	408	[92.7]	1045	[237.3]
900	[62.1]	42	[9.5]	169	[38.4]	433	[98.3]	1108	[251.6]
1000	[68.9]	44	[10.0]	178	[40.4]	456	[103.6]	1168	[265.3]
1250	[86.2]	50	[11.4]	199	[45.2]	510	[115.8]	1306	[296.6]
1500	[103.4]	54	[12.3]	218	[49.5]	559	[127.0]	1430	[324.8]
1750	[120.6]	59	[13.4]	235	[53.4]	604	[137.2]	—	—
2000	[137.9]	63	[14.3]	252	[57.2]	645	[146.5]	—	—
2250	[155.1]	67	[15.2]	267	[60.6]	685	[155.6]	—	—
2500 ²	[172.4]	70	[15.9]	281	[63.8]	722	[164.0]	—	—
2750 ²	[189.6]	74	[16.8]	295	[67.0]	757	[171.9]	—	—
3000 ²	[206.9]	77	[17.5]	308	[70.0]	791	[179.6]	—	—
4000 ²	[275.8]	89	[20.2]	356	[80.8]	913	[207.3]	—	—
5000 ²	[344.8]	99	[22.5]	398	[90.4]	1021	[231.9]	—	—
6000 ²	[413.7]	109	[24.8]	436	[99.0]	1118	[253.9]	—	—

Notes

- 70°F [21°C], 10% overpressure.
- Metric conversions:
 barg = psig × 0.06895
 cm² = in² × 6.4516
 M³/hr = GPM × 0.2271
 °C = [°F - 32] × 0.5556

Appendix

Type 61 Capacities

Type 61 Capacities¹ - SCFM [Nm³/hr]

Set Pressure psig [barg]	Air, National Board Certified -6 0.110 in ² [0.71 cm ²]		Natural Gas ² -6 0.110 in ² [0.71 cm ²]	
	30 [2.07]	84	[135.1]	105
40 [2.76]	104	[167.2]	130	[209.0]
60 [4.13]	143	[229.9]	178	[286.2]
80 [5.52]	182	[292.7]	227	[365.0]
100 [6.90]	221	[355.4]	275	[442.2]
120 [8.27]	260	[418.1]	324	[521.0]
140 [9.65]	299	[480.8]	372	[598.2]
160 [11.0]	338	[543.5]	421	[677.0]
180 [12.4]	376	[604.6]	470	[755.8]
200 [13.8]	415	[667.3]	518	[832.9]
220 [15.2]	454	[730.0]	567	[911.7]
240 [16.5]	493	[792.7]	615	[988.9]
260 [17.9]	532	[855.5]	664	[1067.7]
280 [19.3]	571	[918.2]	712	[1144.9]
300 [20.7]	610	[980.9]	761	[1223.7]
320 [22.1]	649	[1043.6]	809	[1300.9]
340 [23.4]	688	[1106.3]	858	[1379.7]
360 [24.8]	727	[1169.0]	907	[1458.5]
380 [26.2]	766	[1231.7]	955	[1535.6]
400 [27.6]	805	[1294.4]	1004	[1614.4]
420 [29.0]	844	[1357.2]	1052	[1691.6]
440 [30.3]	883	[1419.9]	1101	[1770.4]
460 [31.7]	922	[1482.6]	1149	[1847.6]
480 [33.1]	961	[1545.3]	1198	[1926.4]
500 [34.5]	1000	[1608.0]	1247	[2005.2]

Notes

- 60°F [16°C], Z = 1.00; 10% overpressure.
- Molecular weight = 17.4.
- Metric conversions:
 barg = psig x 0.06895
 cm² = in² x 6.4516
 °C = [°F - 32] x 0.5556
 Nm³/hr = SCFM x 1.608

Appendix
Type 63B Capacities

Type 63B Capacities ¹ - SCFM [Nm ³ /hr]									
Set Pressure psig [barg]	Air, National Board Certified					Natural Gas ²			
	-5		-7		-5		-7		
	0.077 in ² [0.497 cm ²]		0.150 in ² [0.968 cm ²]		0.077 in ² [0.497 cm ²]		0.150 in ² [0.968 cm ²]		
40	[2.76]	69	[111.0]	—	—	86	[138.3]	—	—
60	[4.14]	95	[152.8]	191	[307.1]	119	[191.4]	238	[382.7]
80	[5.52]	121	[194.6]	243	[390.7]	151	[242.8]	303	[487.2]
100	[6.90]	147	[236.4]	296	[476.0]	183	[294.3]	368	[591.7]
120	[8.27]	173	[278.2]	348	[559.6]	216	[347.3]	433	[696.3]
140	[9.65]	199	[320.0]	400	[643.2]	248	[398.8]	498	[800.8]
160	[11.03]	225	[361.8]	452	[726.8]	280	[450.2]	563	[905.3]
180	[12.41]	251	[403.6]	504	[810.4]	313	[503.3]	628	[1009.8]
200	[13.79]	277	[445.4]	556	[894.0]	345	[554.8]	693	[1114.3]
220	[15.17]	303	[487.2]	608	[977.7]	377	[606.2]	758	[1218.9]
240	[16.55]	329	[529.0]	661	[1062.9]	410	[659.3]	823	[1323.4]
260	[17.92]	355	[570.8]	713	[1146.5]	442	[710.7]	888	[1427.9]
280	[19.31]	381	[612.6]	765	[1230.1]	474	[762.2]	953	[1532.4]
300	[20.69]	407	[654.5]	817	[1313.7]	507	[815.3]	1018	[1636.9]
320	[22.06]	433	[696.3]	869	[1397.4]	539	[866.7]	1082	[1739.9]
340	[23.44]	459	[738.1]	921	[1481.0]	571	[918.2]	1147	[1844.4]
360	[24.82]	485	[779.9]	973	[1564.6]	604	[971.2]	1212	[1948.9]
380	[26.20]	511	[821.7]	—	—	636	[1022.7]	—	—
400	[27.58]	537	[863.5]	—	—	668	[1074.1]	—	—
420	[28.96]	563	[905.3]	—	—	701	[1127.2]	—	—
440	[30.34]	588	[945.5]	—	—	733	[1178.7]	—	—
460	[31.72]	614	[987.3]	—	—	765	[1230.1]	—	—
480	[33.10]	640	[1029.1]	—	—	798	[1283.2]	—	—
500	[34.48]	666	[1070.9]	—	—	830	[1334.6]	—	—
520	[35.85]	692	[1112.7]	—	—	862	[1386.1]	—	—

Notes

- 60°F [16°C], Z = 1.00; 10% overpressure.
- Molecular weight = 17.4.
- Metric conversions:
barg = psig x 0.06895
cm² = in² x 6.4516
°C = [°F - 32] x 0.5556
Nm³/hr = SCFM x 1.608

Appendix

Seat Tightness Performance Specifications

All pressure relief valves are checked for seat leakage per procedures outlined in API 527.

The following operating pressures will allow for bubble-tight seat sealing performance.

Valve Type	Set Pressure Range	Operating Pressure Range
81 and 83	100 psig [6.9 barg] and above	0% to 95% of set
	50 to 99 psig [3.4 to 6.8 barg]	0% to 90% of set
	Below 50 psig [3.4 barg]	0% to 85% of set
81P	100 psig [6.9 barg] and above	0% to 92.5% of set
	Below 100 psig [6.9 barg]	0% to 80% of set
86	100 psig [6.9 barg] and above	0% to 95% of set
	50 to 99 psig [3.4 to 6.8 barg]	0% to 90% of set
61 and 63	100 psig [6.9 barg] and above	0% to 95% of set
	Below 100 psig [6.9 barg]	0% to 90% of set

Tyco Flow Control (TFC) provides the information herein in good faith but makes no representation as to its comprehensiveness or accuracy. This data sheet is intended only as a guide to TFC products and services. Individuals using this data sheet must exercise their independent judgment in evaluating product selection and determining product appropriateness for their particular purpose and system requirements. TFC MAKES NO REPRESENTATIONS OR WARRANTIES, EITHER EXPRESS OR IMPLIED, INCLUDING WITHOUT LIMITATION ANY WARRANTIES OF MERCHANTABILITY OR FITNESS FOR A PARTICULAR PURPOSE WITH RESPECT TO THE INFORMATION SET FORTH HEREIN OR THE PRODUCT(S) TO WHICH THE INFORMATION REFERS. ACCORDINGLY, TFC WILL NOT BE RESPONSIBLE FOR DAMAGES (OF ANY KIND OR NATURE, INCLUDING INCIDENTAL, DIRECT, INDIRECT, OR CONSEQUENTIAL DAMAGES) RESULTING FROM THE USE OF OR RELIANCE UPON THIS INFORMATION. Patents and Patents Pending in the U.S. and foreign countries. Tyco reserves the right to change product designs and specifications without notice. All registered trademarks are the property of their respective owners. Printed in the USA.