



The Varec 2010B/2020B protects tanks from damage or deformation, and minimizes emissions to the environment, as well as loss of product due to evaporation.

Introduction

The Varec 2010B and 2020B Pressure and Vacuum Relief Valves are designed for use on atmospheric and low pressure storage tanks. The 2010B vents to atmosphere. The 2020B allows vapors to be piped away for recovery or destruction.

The primary function of both models is to protect the tank from physical damage or permanent deformation caused by increases in internal pressure or vacuum encountered in normal operations. On smaller tanks, the valve may also provide sufficient flow capacity for emergency venting. The "air-cushion" seating design keeps the valve tightly sealed until the pressure inside the tank approaches the valve setting. Valve selection should be in accordance with American Petroleum Institute Standard 2000 or other applicable standard.

Flow curves are provided to help you select the proper valve size for your venting requirements. Additionally, Varec's applications engineering staff and factory trained representatives are always available to assist you.

By controlling tank venting, the 2010B and 2020B not only minimize emissions to the environment, but also minimize the loss of product to evaporation. When combined with a well-designed vapor recovery system, the loss can be cut to essentially zero.

An "All-Weather" option is offered for freezing climates. The design features a special non-frosting and icing-resistant coating on the pallet perimeter, stem, guide posts and tip-of-seat ring. The coating, along with the flexible Teflon® seat insert, provides additional protection against pallets freezing closed.

For high temperature and chemical applications, Varec recommends one of the extended service options, which offers the selection of O-ring, gasket, and screen material.

Features

- The pressure and vacuum ports are oversized to provide maximum flow capacity.
- The hood and cover can be easily removed for inspection and maintenance.
- The seat rings are both interchangeable and field replaceable.
- Protective screens are provided at pressure and vacuum ports to help prevent entrance of foreign matter.
- The outlet adapter on the 2020B Series is one pipe size larger than the valve inlet flange to optimize flow capacity.



The 2010B and 2020B are part of Varec's modular products which use interchangeable components for assembling a variety of functional configurations. The modular design provides flexibility of field installation and allows the valve to be reconfigured, repaired and even upgraded on-site by simply replacing or adding components.

Available Materials

- Aluminum
- Carbon Steel
- Stainless Steel
- Ductile Iron
- Special Materials on Application

Technical Data

- 2" to 12" [50 - 300 mm] sizes available.
- Vent to atmosphere or pipe away model.
- Oversized pressure and vacuum ports.
- Optional "All-Weather" coating of valve seats and guides.
- Extended service available for chemical applications.
- Replaceable and interchangeable pressure and vacuum seat rings.
- Leakage rate of 1 SCFH [0.03 Nm³/hr] or less at 90% of setpoint.
- Pressure settings up to 2 psig [0.14 barg].

Specifications

The 2010B and 2020B Series Pressure and Vacuum Relief Valves are available in a variety of configurations to meet your specific needs.

Sizes

2010B/2011B:	2" [50 mm]
	3" [80 mm]
	4" [100 mm]
	6" [150 mm]
	8" [200 mm]
	10" [250 mm]
12" [300 mm]	

2020B/2021B:	2" x 3"
	3" x 4"
	4" x 6"
	6" x 8"
	8" x 10"
	10" x 12"
12" x 14"	

Flanged Connections – Standard Flange Drilling

Aluminum

Drilled to ANSI/ASA Class 125 dimensions (Flat Face)

Drilled to DIN 2633 [16 Bar] dimensions (Flat Face)

CS, DI and SS Body

Drilled to ANSI Class 150 dimensions (Raised or Flat Face)

Drilled to Imperial DIN 2633 [16 Bar] dimensions (Raised or Flat Face)

Drilled to JPI or JIS (Raised or Flat Face) - consult your sales representative

Mounting Studs

Fractional (Imperial)

Metric

Testing

Each valve is tested for proper setting and for a leakage rate of less than 1 SCFH (0.03 Nm³/hr) of air at 90 percent of the set point. Each valve is tested for leak tightness at 75 percent of set point as required in API Standard 2000.

Parts and Materials Table (see page 3)

Material Code

Item	1	2	3	4	5
1 Body	Aluminum	Aluminum	Carbon Steel	316 SS	Ductile Iron
2 Weatherhood	Aluminum	Aluminum	Carbon Steel	316 SS	Carbon Steel
3 Guide Stem	Aluminum	316 SS	316 SS	316 SS	316 SS
4 Guide Posts	316 SS	316 SS	316 SS	316 SS	316 SS
5 Pallet	Aluminum	316 SS	316 SS	316 SS	316 SS
6 Seat Ring	Aluminum	316 SS	316 SS	316 SS	316 SS
7 Seat Ring Retainer ¹	Polypropylene	Polypropylene	Polypropylene	Polypropylene	Polypropylene
8 Insert ¹	Teflon®	Teflon®	Teflon®	Teflon®	Teflon®
9 Insert Retainer	Aluminum	316 SS	316 SS	316 SS	316 SS
10 Screen ¹	HDPE	HDPE	HDPE	HDPE	HDPE
11 Gaskets ¹	Fiber	Fiber	Fiber	Fiber	Fiber
12 O-ring ¹	BUNA-N	BUNA-N	BUNA-N	BUNA-N	BUNA-N
13 Weights	Lead	Lead	Lead	Lead	Lead

Notes

1. Materials are as standard. See model option code for other materials and their associated temperature ranges.
2. Teflon® coated aluminum may be supplied with material codes 2 - 5 to achieve lower settings.
3. All nuts and cap screws are 316 SS.

Parts and Materials

2010B (see page 2)

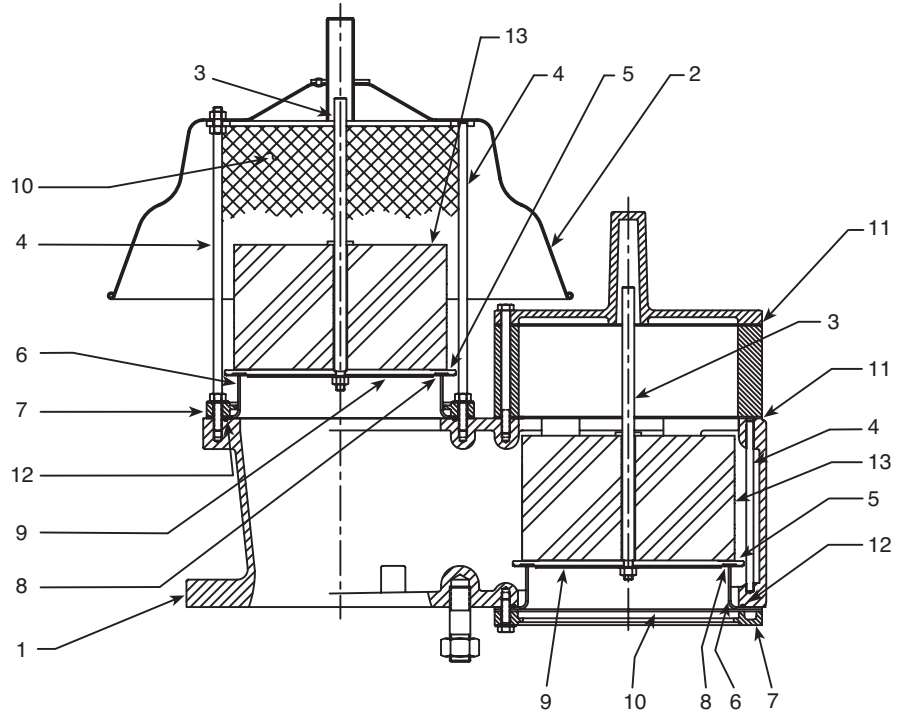

2020B (see page 2)

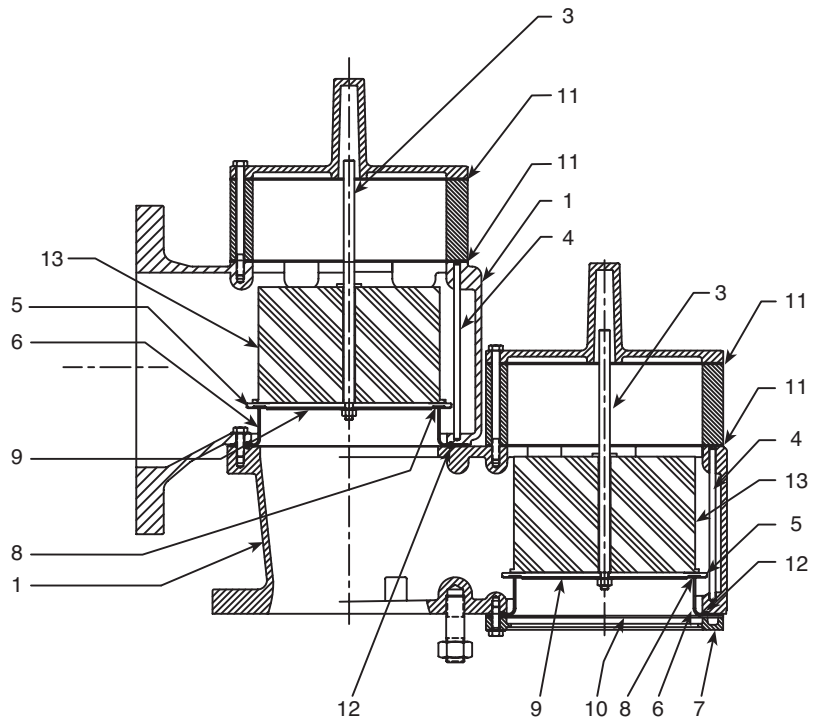

Specifications

Setting Information

Size	Minimum Pressure Set, oz/in ²		Minimum Vacuum Set, oz/in ²		Low Set Range		High Set Range	
	Aluminum	316 SS	Aluminum	316 SS	Pressure	Vacuum	Pressure	Vacuum
2010B								
2"	0.29	0.70	0.26	0.62	Min to 16 oz/in ²	Min to 10 oz/in ²	16.01 oz/in ² to 2 psig	10.01 oz/in ² to 2 psig
3"	0.23	0.55	0.21	0.49	Min to 16 oz/in ²	Min to 10 oz/in ²	16.01 oz/in ² to 2 psig	10.01 oz/in ² to 2 psig
4"	0.29	0.60	0.27	0.56	Min to 16 oz/in ²	Min to 16 oz/in ²	16.01 oz/in ² to 2 psig	16.01 oz/in ² to 2 psig
6"	0.26	0.61	0.26	0.61	Min to 16 oz/in ²	Min to 16 oz/in ²	16.01 oz/in ² to 2 psig	16.01 oz/in ² to 2 psig
8"	0.25	0.55	0.25	0.55	Min to 16 oz/in ²	Min to 16 oz/in ²	16.01 oz/in ² to 2 psig	16.01 oz/in ² to 2 psig
10"	0.25	0.63	0.25	0.63	Min to 16 oz/in ²	Min to 16 oz/in ²	16.01 oz/in ² to 2 psig	16.01 oz/in ² to 2 psig
12"	0.23	0.59	0.23	0.59	Min to 16 oz/in ²	Min to 16 oz/in ²	16.01 oz/in ² to 2 psig	16.01 oz/in ² to 2 psig

2011B								
2"	0.29	0.70	0.26	0.62	Min to 16 oz/in ²	Min to 10 oz/in ²	16.01 oz/in ² to 2 psig	10.01 oz/in ² to 2 psig
3"	0.23	0.55	0.21	0.49	Min to 16 oz/in ²	Min to 10 oz/in ²	16.01 oz/in ² to 2 psig	10.01 oz/in ² to 2 psig
4"	0.29	0.60	0.27	0.56	Min to 16 oz/in ²	Min to 16 oz/in ²	16.01 oz/in ² to 2 psig	16.01 oz/in ² to 2 psig
6"	0.26	0.61	0.26	0.61	Min to 16 oz/in ²	Min to 16 oz/in ²	16.01 oz/in ² to 2 psig	16.01 oz/in ² to 2 psig
8"	0.25	0.55	0.25	0.55	Min to 16 oz/in ²	Min to 16 oz/in ²	16.01 oz/in ² to 2 psig	16.01 oz/in ² to 2 psig
10"	0.49	1.33	0.49	1.33	Min to 16 oz/in ²	Min to 16 oz/in ²	16.01 oz/in ² to 2 psig	16.01 oz/in ² to 2 psig
12"	0.47	1.28	0.47	1.28	Min to 16 oz/in ²	Min to 16 oz/in ²	16.01 oz/in ² to 2 psig	16.01 oz/in ² to 2 psig

2020B								
2"	0.26	0.62	0.26	0.62	Min to 10 oz/in ²	Min to 10 oz/in ²	10.01 oz/in ² to 2 psig	10.01 oz/in ² to 2 psig
3"	0.21	0.49	0.21	0.49	Min to 10 oz/in ²	Min to 10 oz/in ²	10.01 oz/in ² to 2 psig	10.01 oz/in ² to 2 psig
4"	0.27	0.56	0.27	0.56	Min to 16 oz/in ²	Min to 16 oz/in ²	16.01 oz/in ² to 2 psig	16.01 oz/in ² to 2 psig
6"	0.26	0.61	0.26	0.61	Min to 16 oz/in ²	Min to 16 oz/in ²	16.01 oz/in ² to 2 psig	16.01 oz/in ² to 2 psig
8"	0.25	0.55	0.25	0.55	Min to 16 oz/in ²	Min to 16 oz/in ²	16.01 oz/in ² to 2 psig	16.01 oz/in ² to 2 psig
10"	0.25	0.63	0.25	0.63	Min to 16 oz/in ²	Min to 16 oz/in ²	16.01 oz/in ² to 2 psig	16.01 oz/in ² to 2 psig
12"	0.23	0.59	0.23	0.59	Min to 16 oz/in ²	Min to 16 oz/in ²	16.01 oz/in ² to 2 psig	16.01 oz/in ² to 2 psig

2021B								
2"	0.26	0.62	0.26	0.62	Min to 10 oz/in ²	Min to 10 oz/in ²	10.01 oz/in ² to 2 psig	10.01 oz/in ² to 2 psig
3"	0.21	0.49	0.21	0.49	Min to 10 oz/in ²	Min to 10 oz/in ²	10.01 oz/in ² to 2 psig	10.01 oz/in ² to 2 psig
4"	0.27	0.56	0.27	0.56	Min to 16 oz/in ²	Min to 16 oz/in ²	16.01 oz/in ² to 2 psig	16.01 oz/in ² to 2 psig
6"	0.26	0.61	0.26	0.61	Min to 16 oz/in ²	Min to 16 oz/in ²	16.01 oz/in ² to 2 psig	16.01 oz/in ² to 2 psig
8"	0.25	0.55	0.25	0.55	Min to 16 oz/in ²	Min to 16 oz/in ²	16.01 oz/in ² to 2 psig	16.01 oz/in ² to 2 psig
10"	0.49	1.33	0.49	1.33	Min to 16 oz/in ²	Min to 16 oz/in ²	16.01 oz/in ² to 2 psig	16.01 oz/in ² to 2 psig
12"	0.47	1.28	0.47	1.28	Min to 16 oz/in ²	Min to 16 oz/in ²	16.01 oz/in ² to 2 psig	16.01 oz/in ² to 2 psig

Lower settings may be available. Please consult your sales representative.

All valves are factory tested for leakage and correct setting prior to shipment. Certification of valve setting is available upon request.

The mixed pressure/vacuum set ranges , 0204 and 0402 (Low Pressure/High Vacuum and High Pressure/Low Vacuum) use heavier pallets, and therefore have higher low set range minimums. For these cases, add the applicable value from the following table to the low set range minimum. (This increase does not apply for 10" and 12" 2011B/2021B.)

Size	Aluminum	316 SST
2"	0.30	0.72
3"	0.27	0.70
4"	0.21	0.62
6"	0.20	0.55
8"	0.21	0.44
10"	0.25	0.61
12"	0.26	0.67

Flow Curves for 2010B Series, Set at 0.865 inch of Water

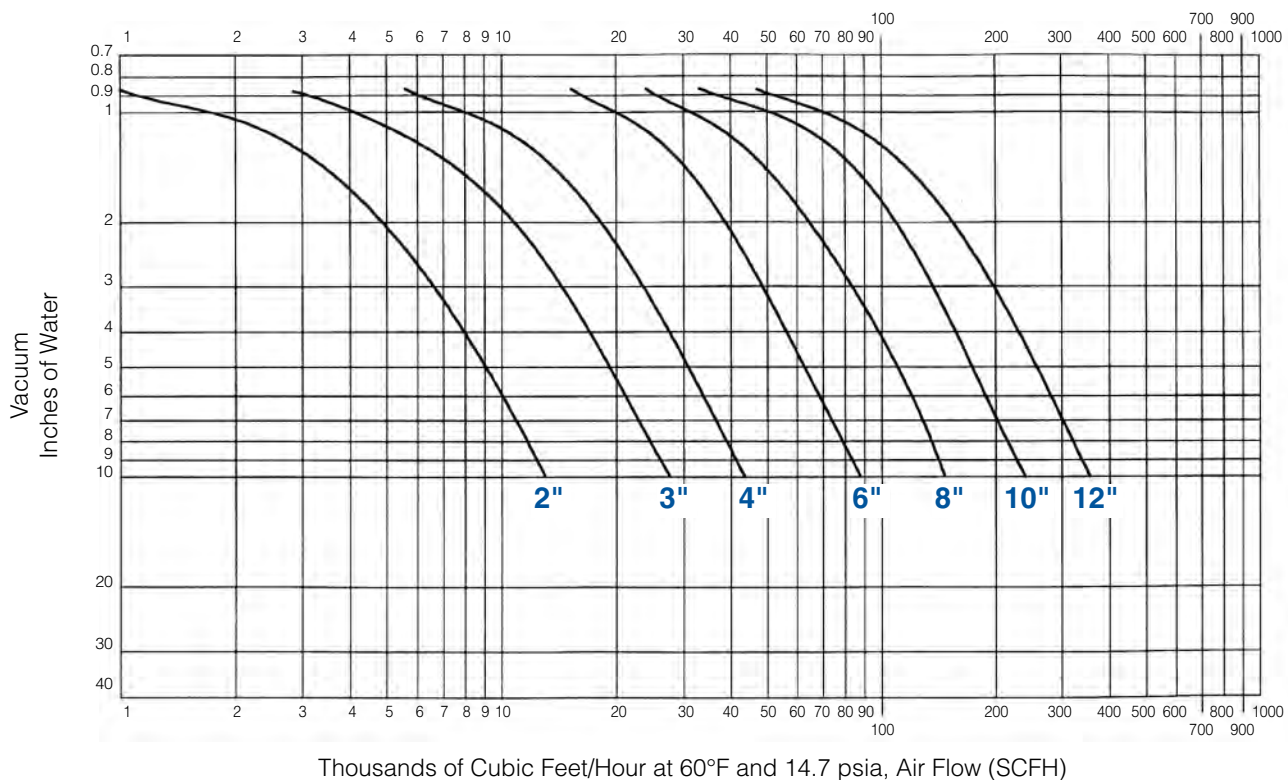
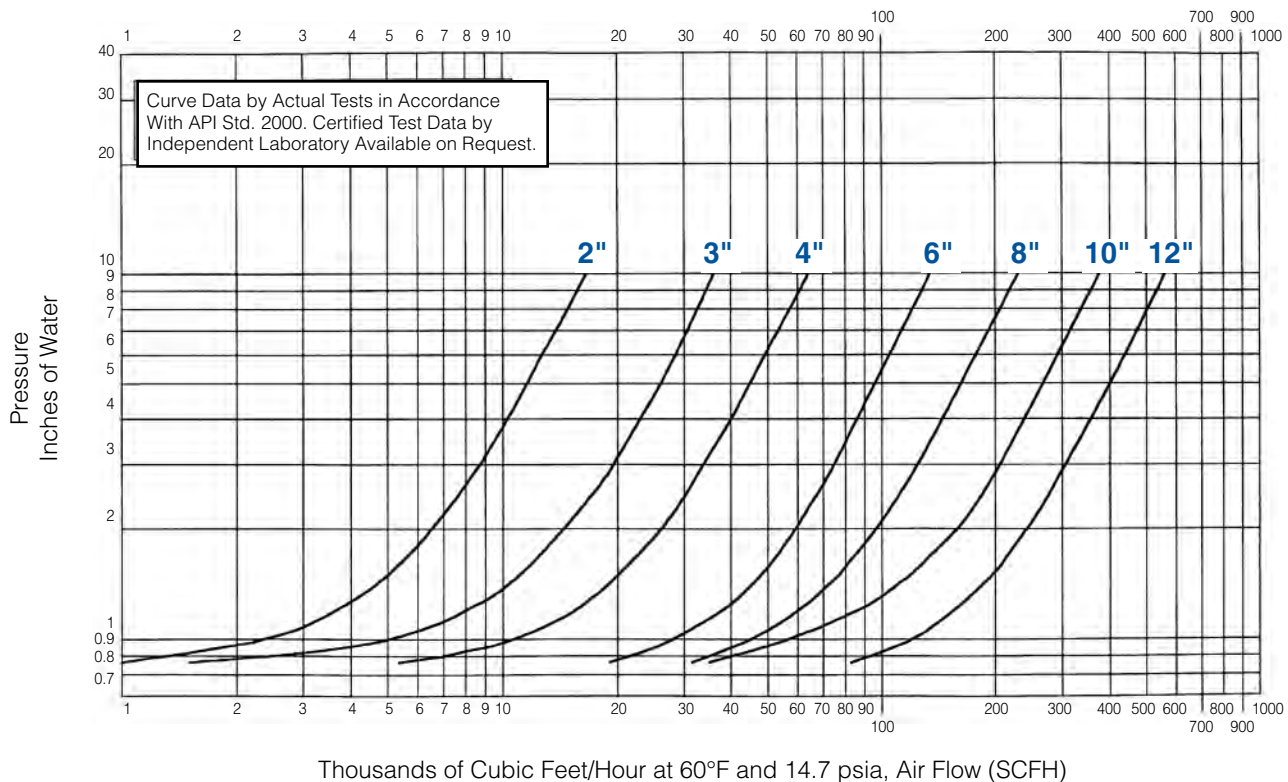

Flow Curves for 2010B Series, Set at 1 inch of Water

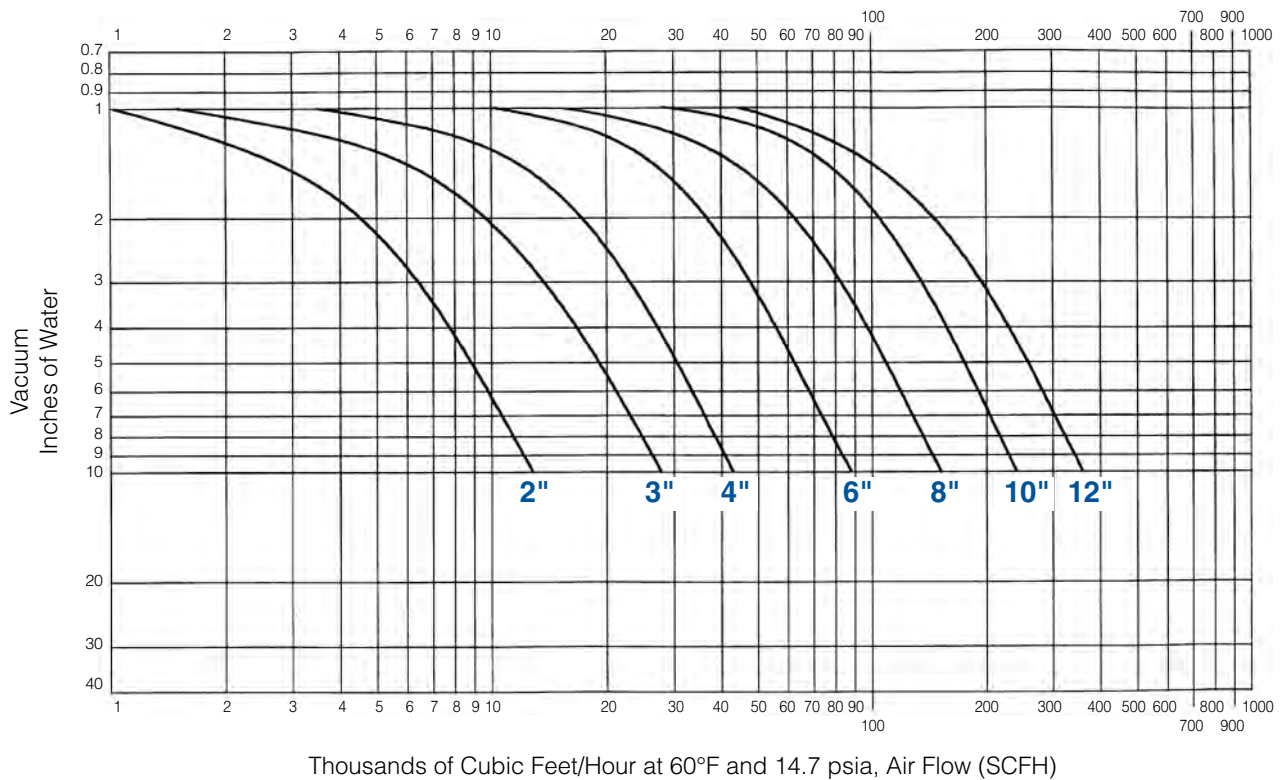
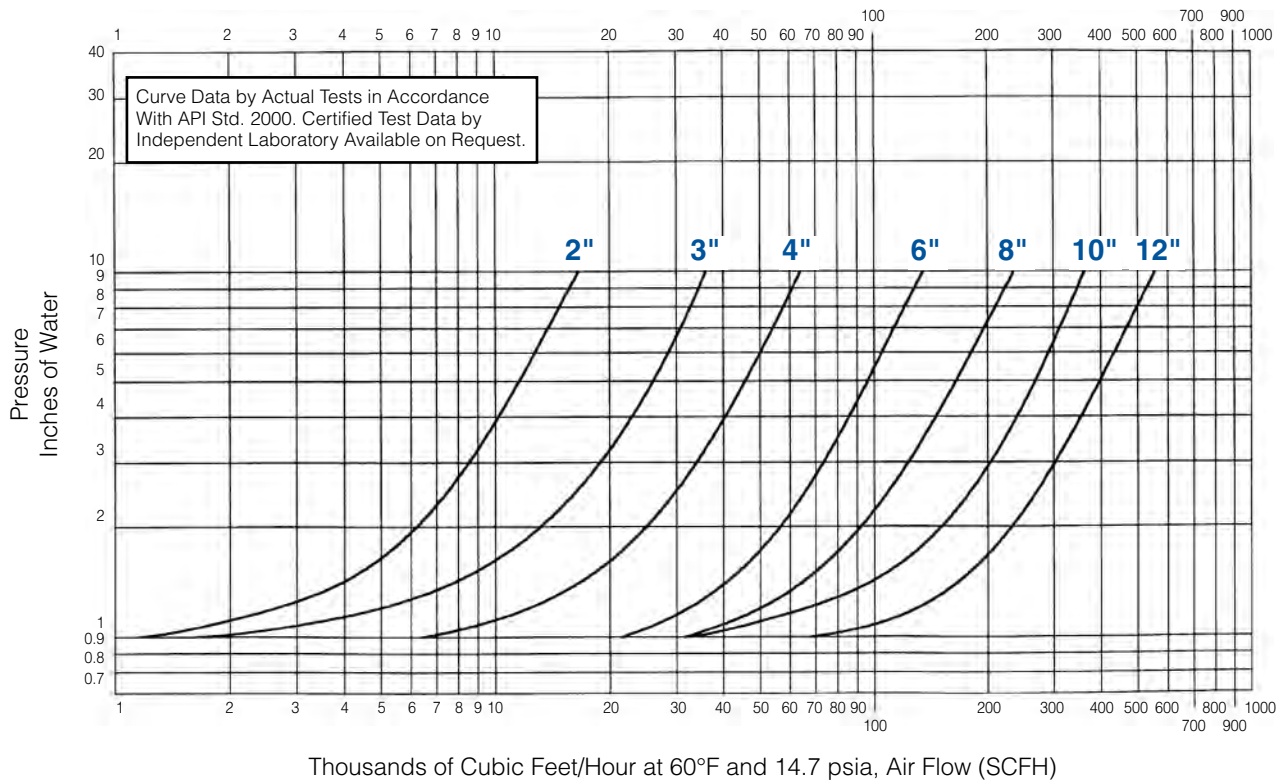

Flow Curves for 2010B Series, Set at 2 inches of Water

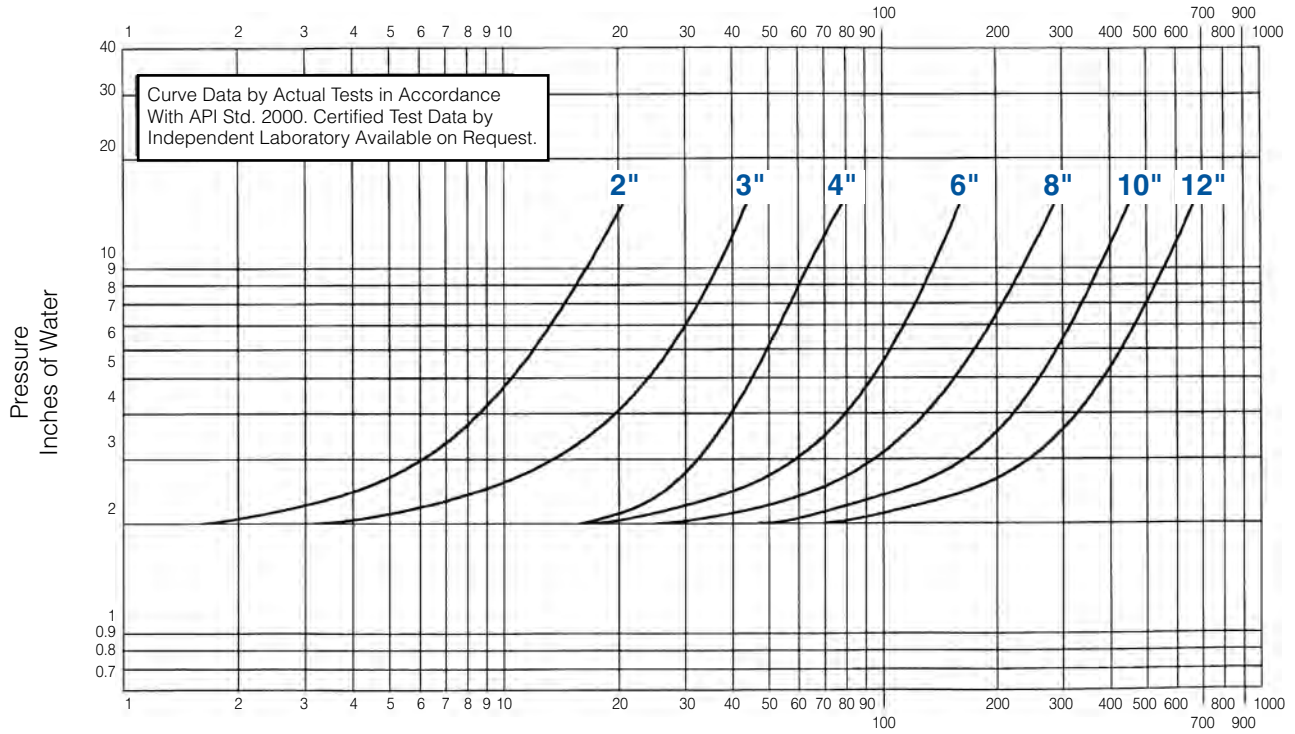

Thousands of Cubic Feet/Hour at 60°F and 14.7 psia, Air Flow (SCFH)

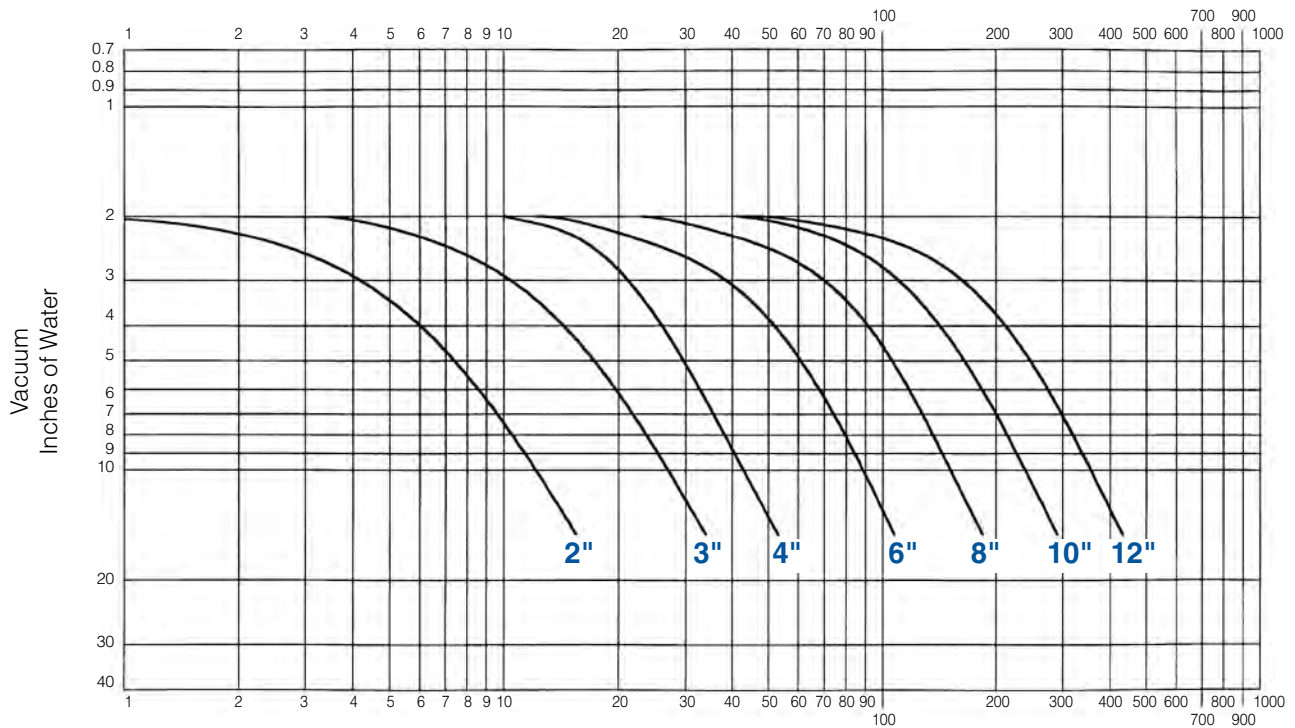

Thousands of Cubic Feet/Hour at 60°F and 14.7 psia, Air Flow (SCFH)

Flow Curves for 2010B Series, Set at 4 inches of Water

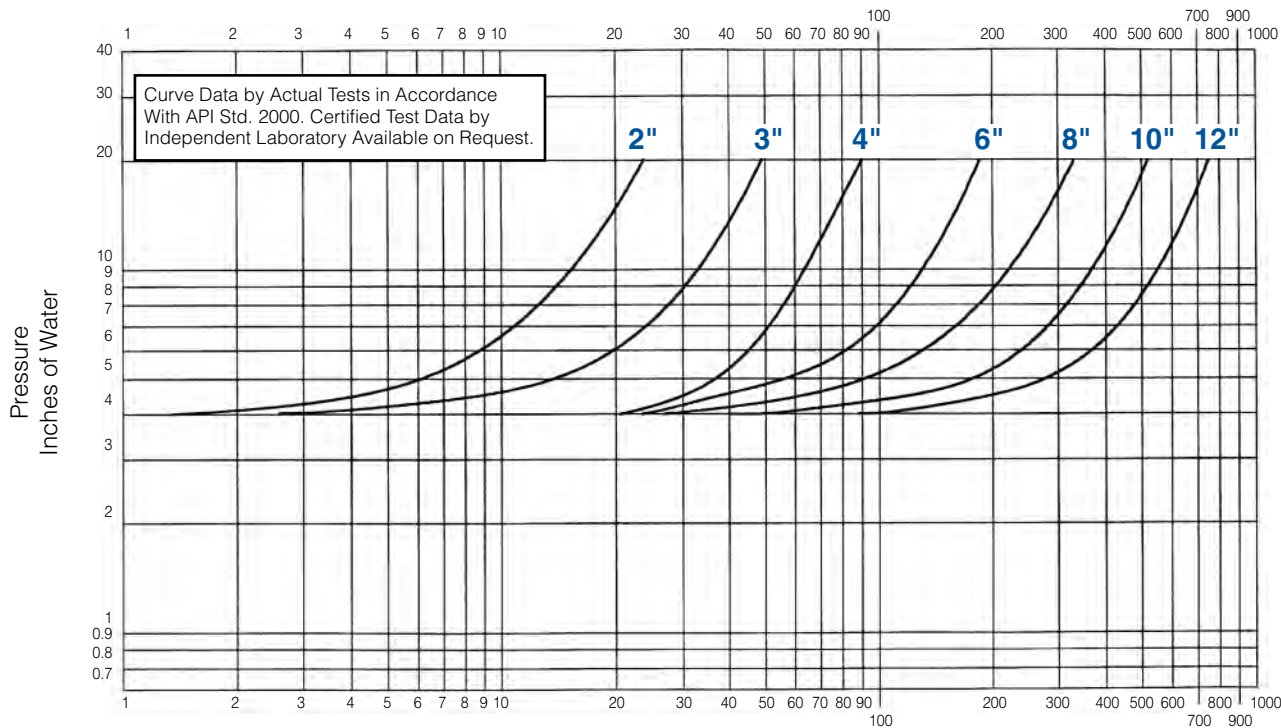

Thousands of Cubic Feet/Hour at 60°F and 14.7 psia, Air Flow (SCFH)

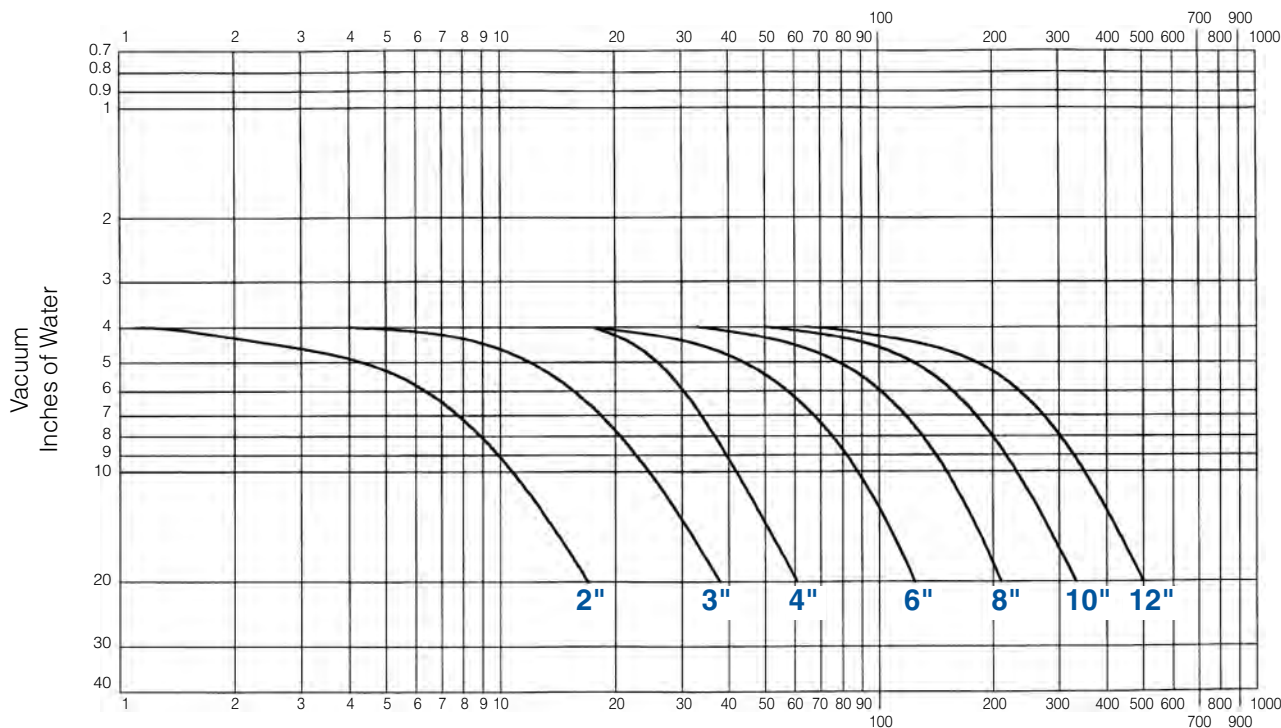

Thousands of Cubic Feet/Hour at 60°F and 14.7 psia, Air Flow (SCFH)

Flow Curves for 2010B Series, Set at 6 inches of Water

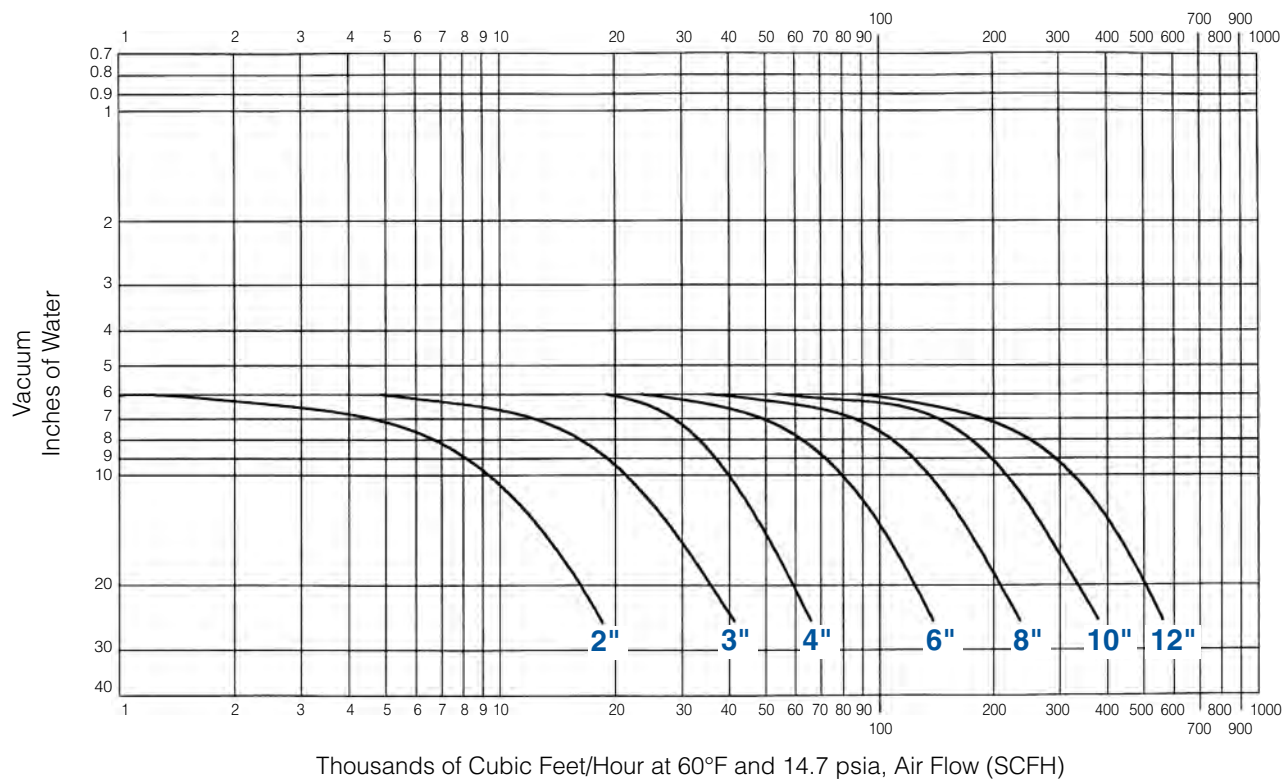
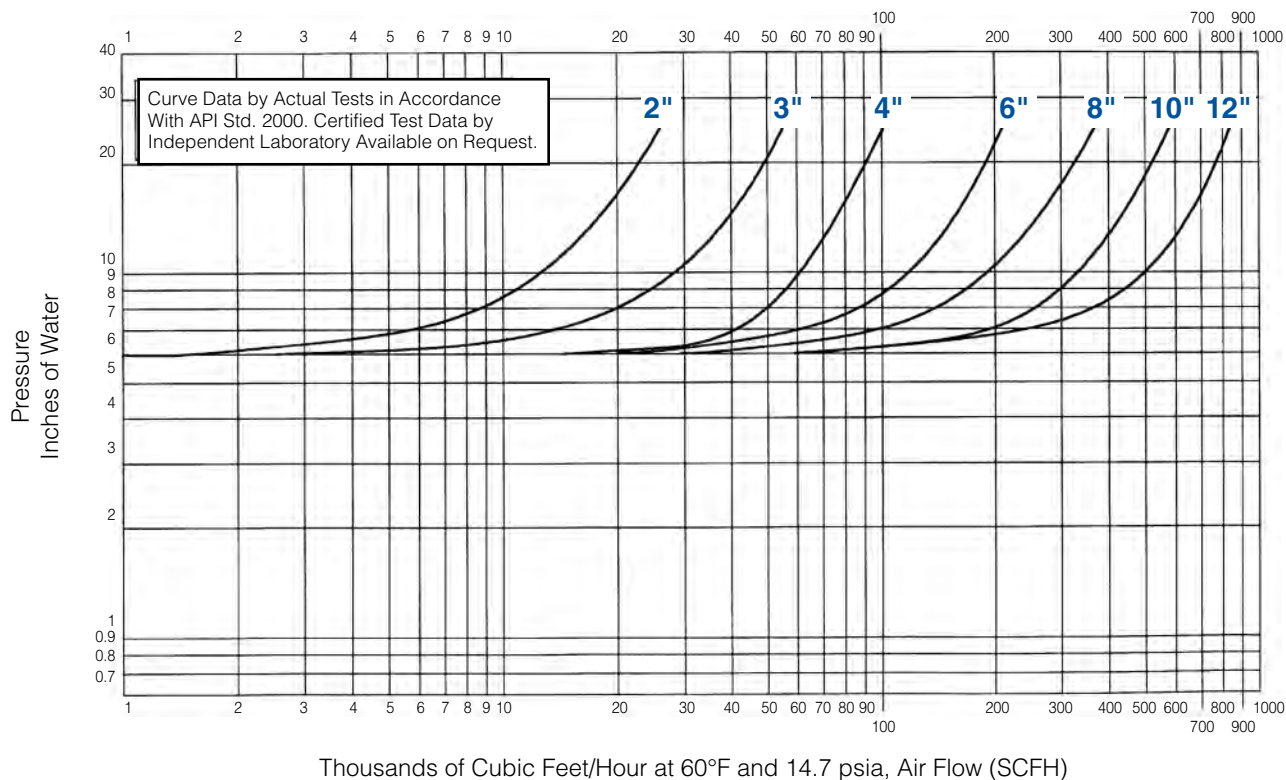

Flow Curves for 2010B Series, Set at 8 inches of Water

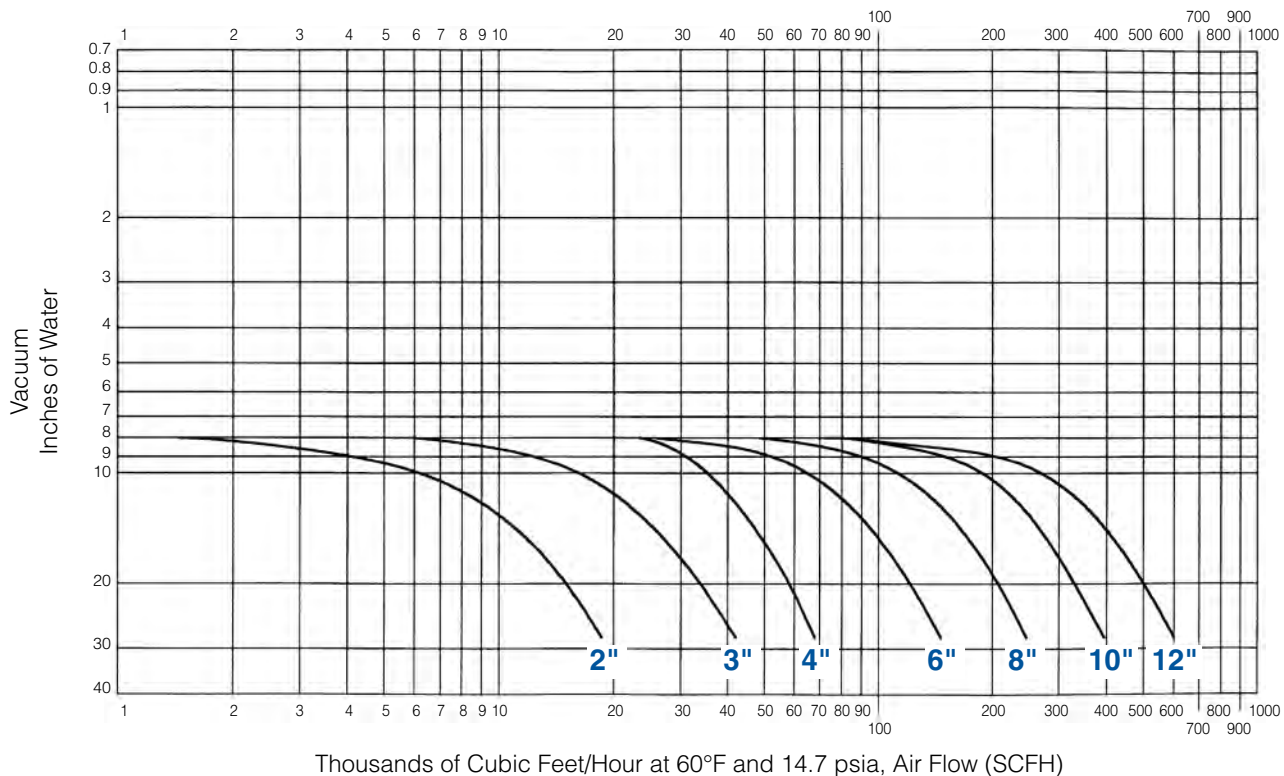
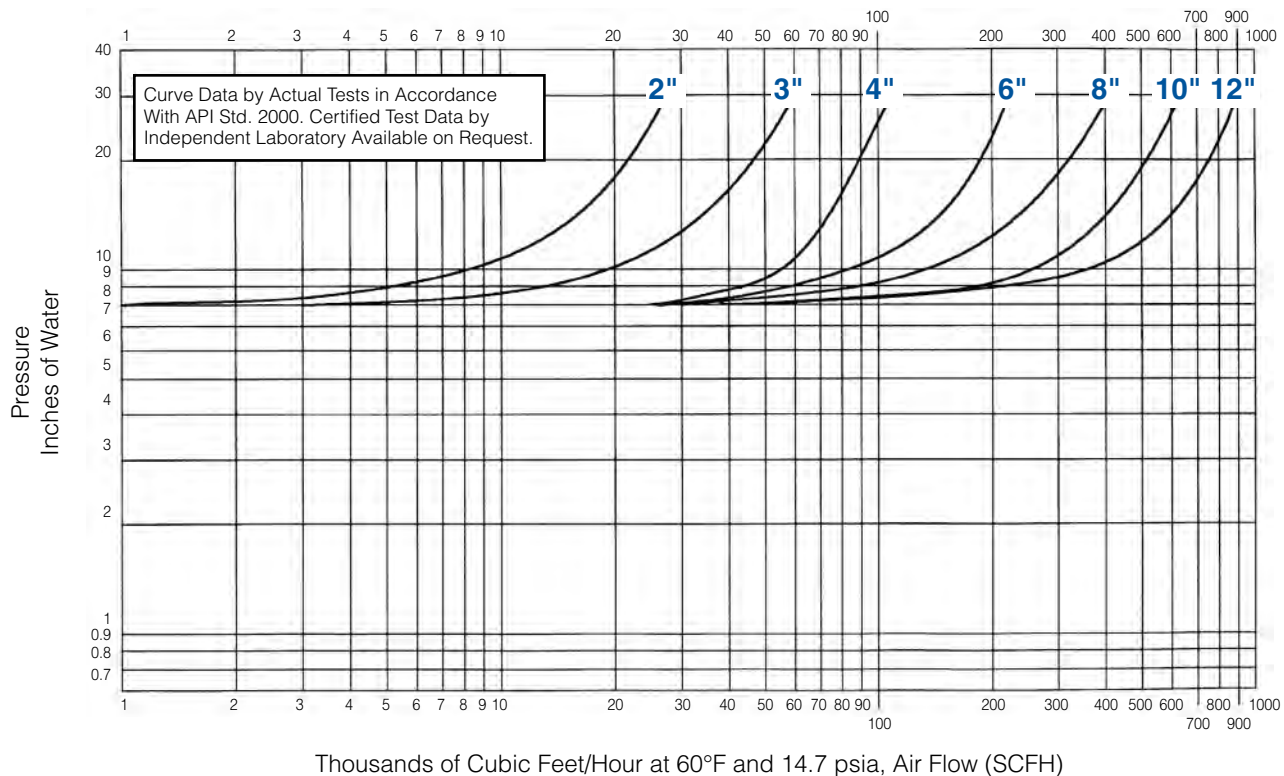

Flow Curves for 2010B Series, Set at 10 inches of Water

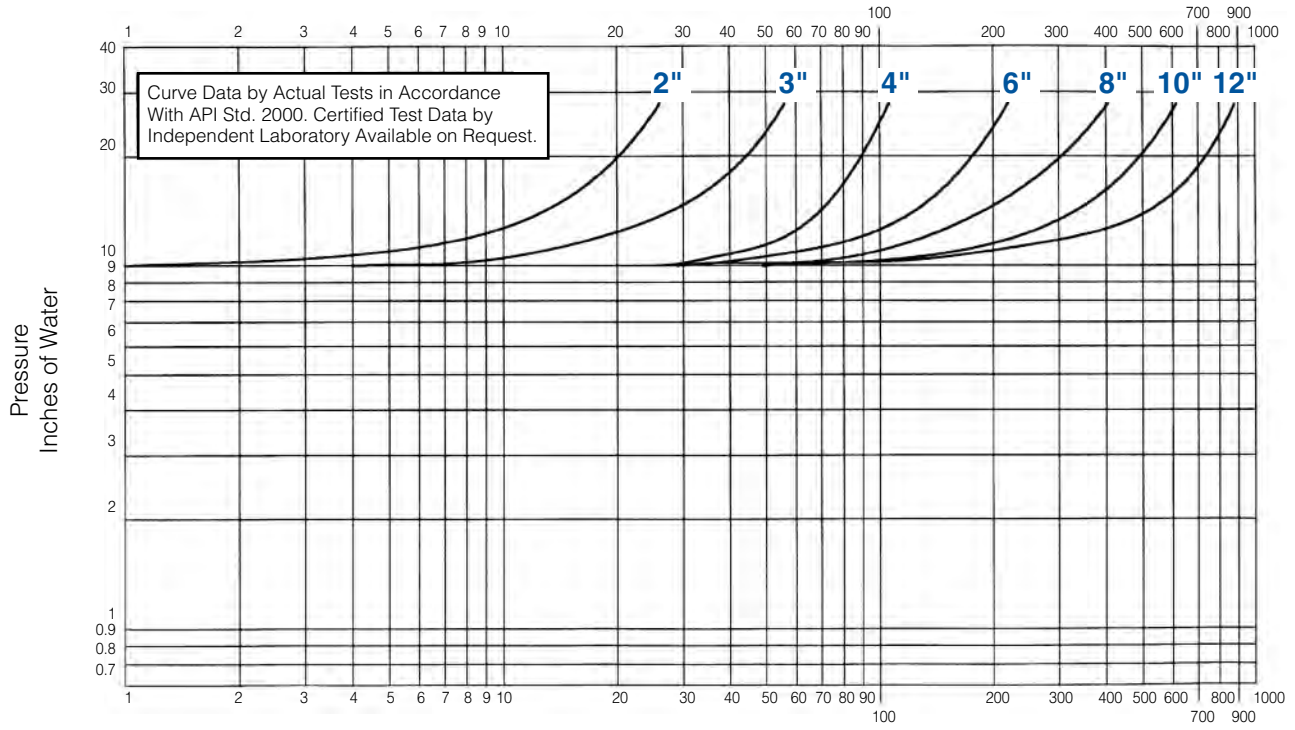

Thousands of Cubic Feet/Hour at 60°F and 14.7 psia, Air Flow (SCFH)

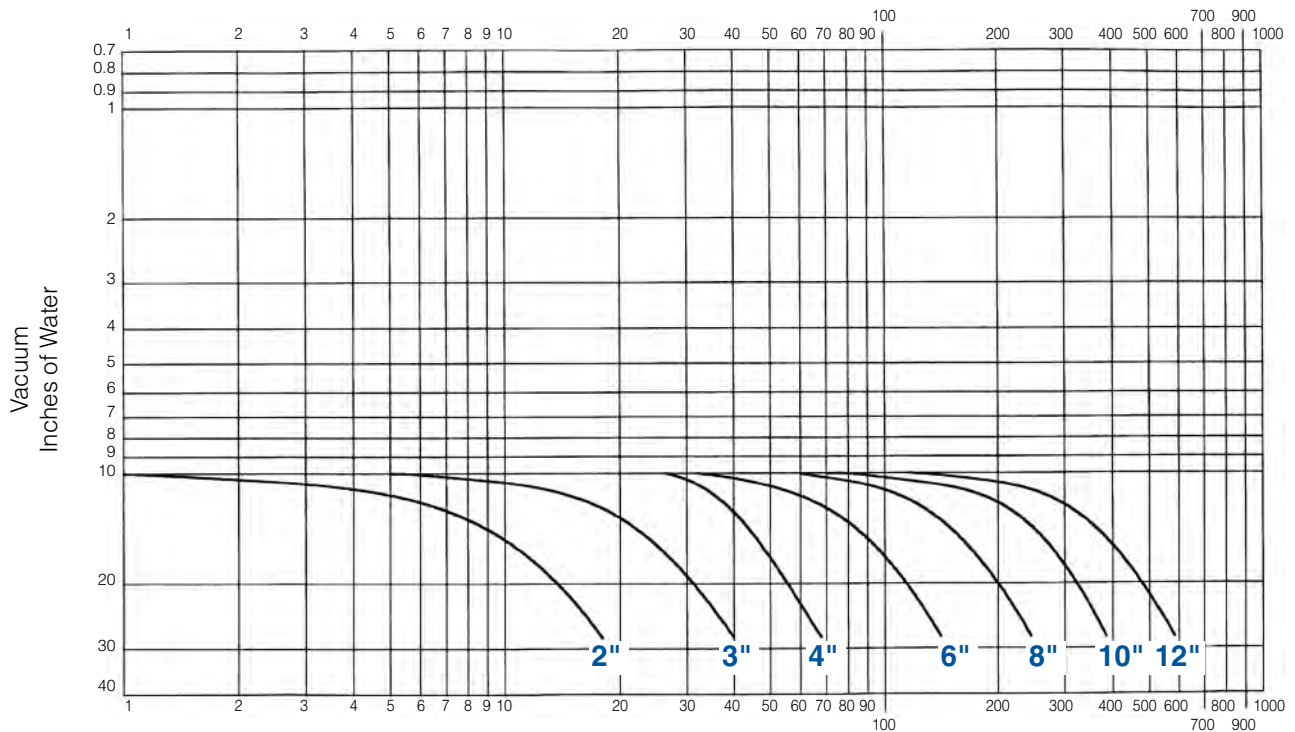

Thousands of Cubic Feet/Hour at 60°F and 14.7 psia, Air Flow (SCFH)

Flow Curves for 2020B Series, Set at 0.865 inch of Water

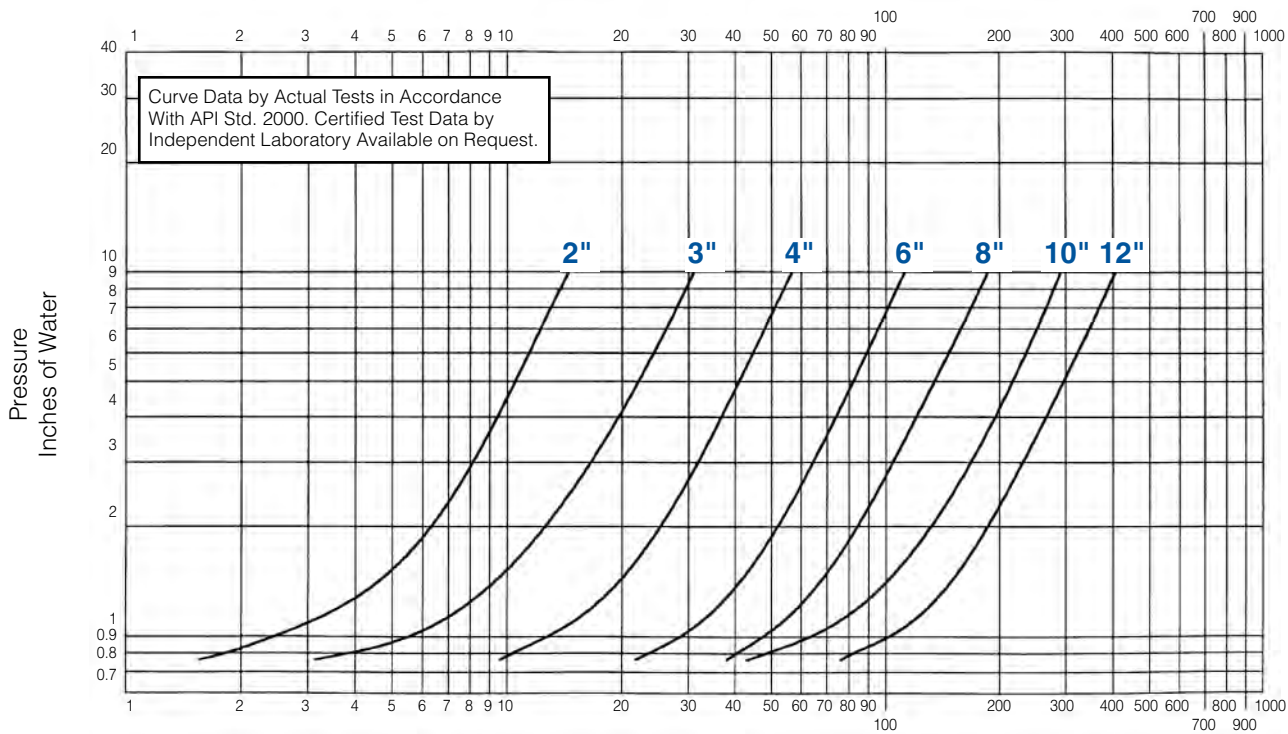

Thousands of Cubic Feet/Hour at 60°F and 14.7 psia, Air Flow (SCFH)

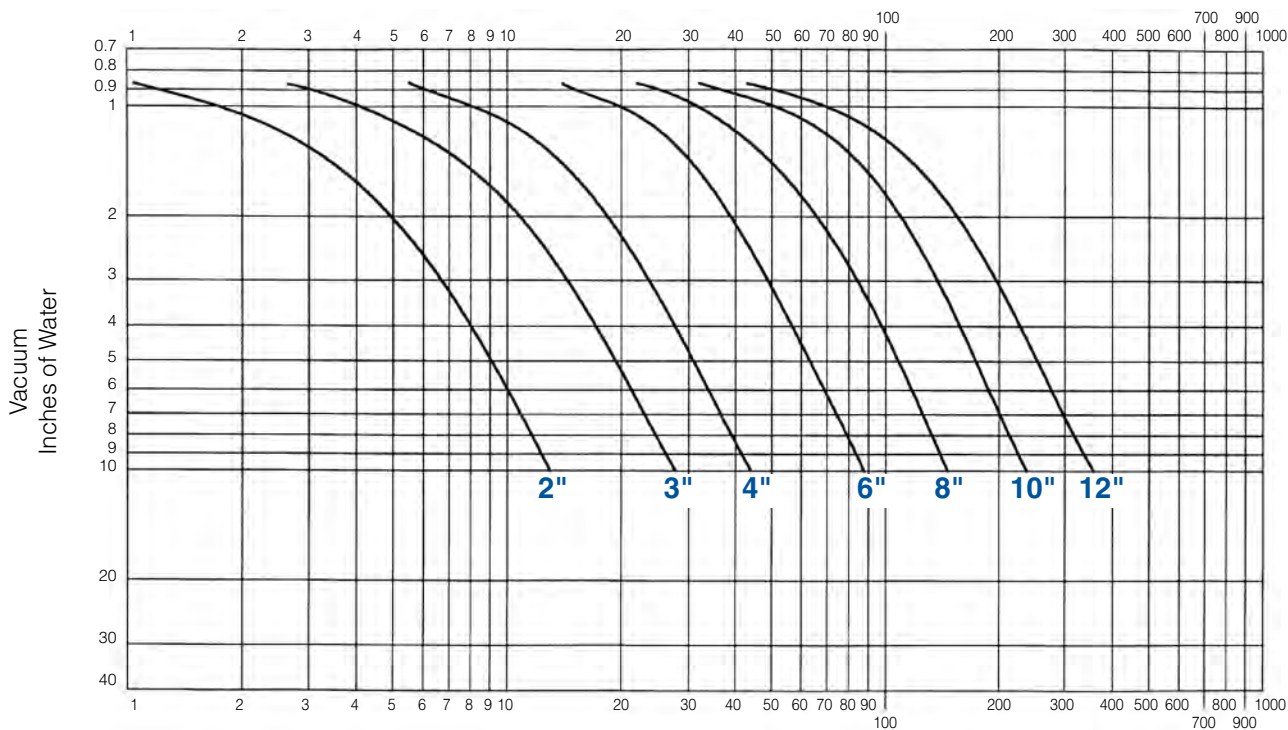

Thousands of Cubic Feet/Hour at 60°F and 14.7 psia, Air Flow (SCFH)

Flow Curves for 2020B Series, Set at 1 inch of Water

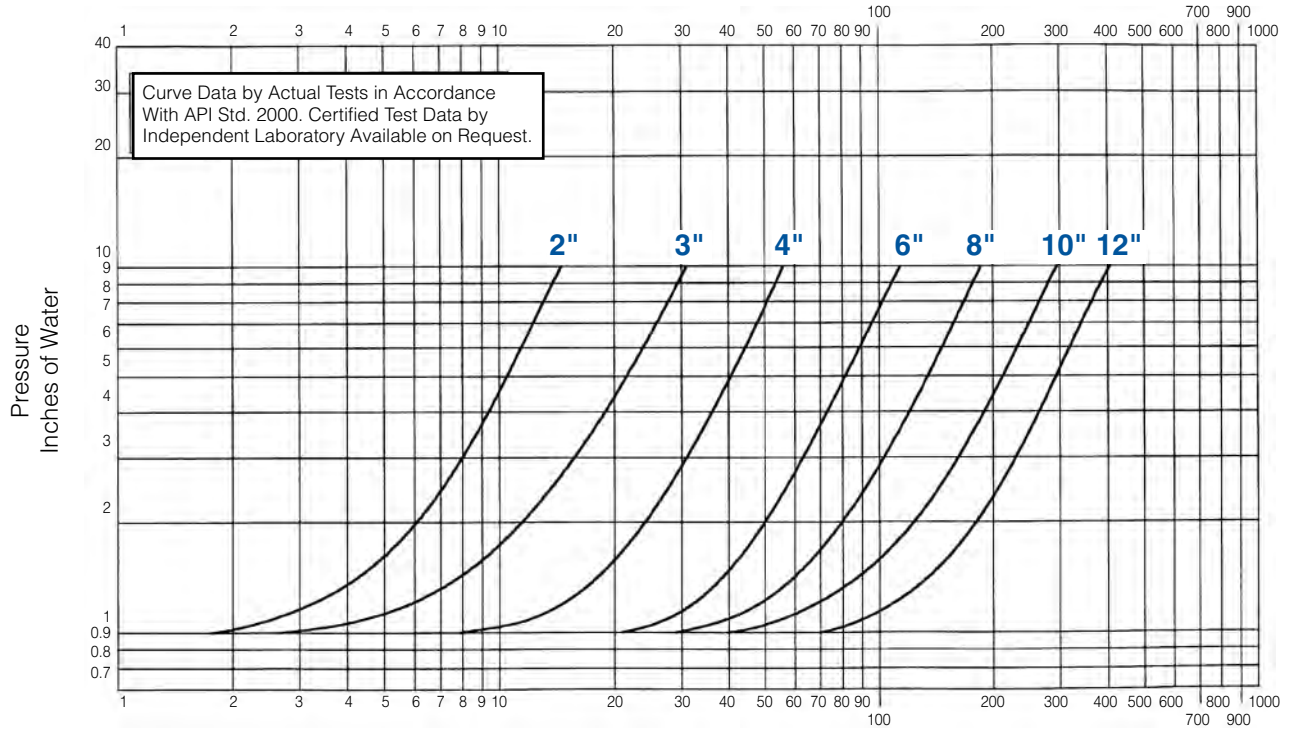

Thousands of Cubic Feet/Hour at 60°F and 14.7 psia, Air Flow (SCFH)

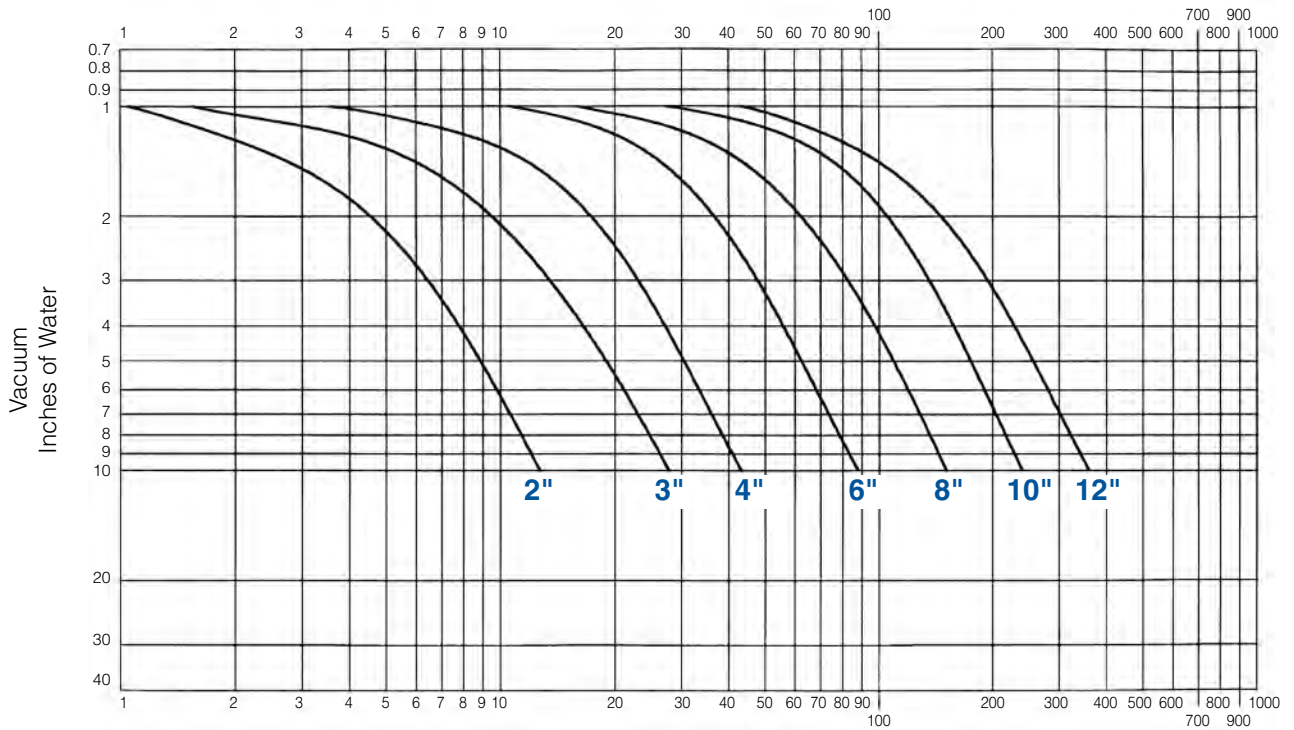

Thousands of Cubic Feet/Hour at 60°F and 14.7 psia, Air Flow (SCFH)

Flow Curves for 2020B Series, Set at 2 inches of Water

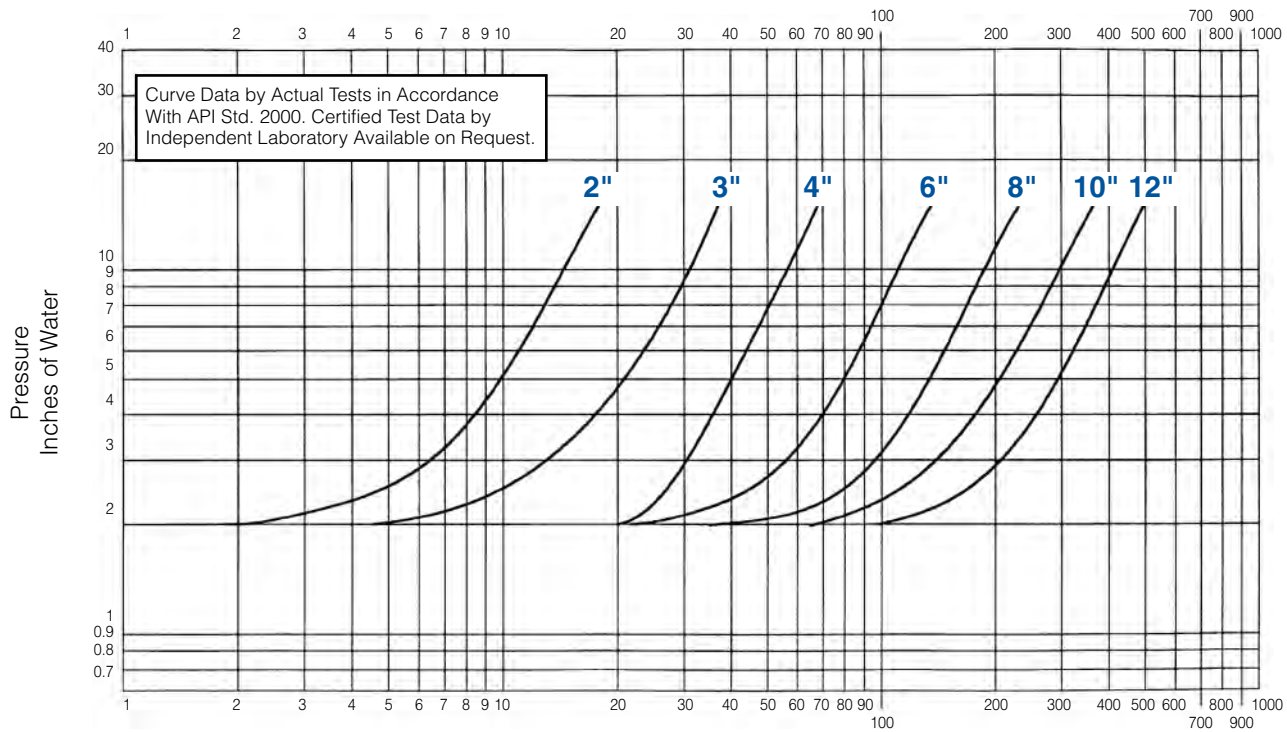

Thousands of Cubic Feet/Hour at 60°F and 14.7 psia, Air Flow (SCFH)

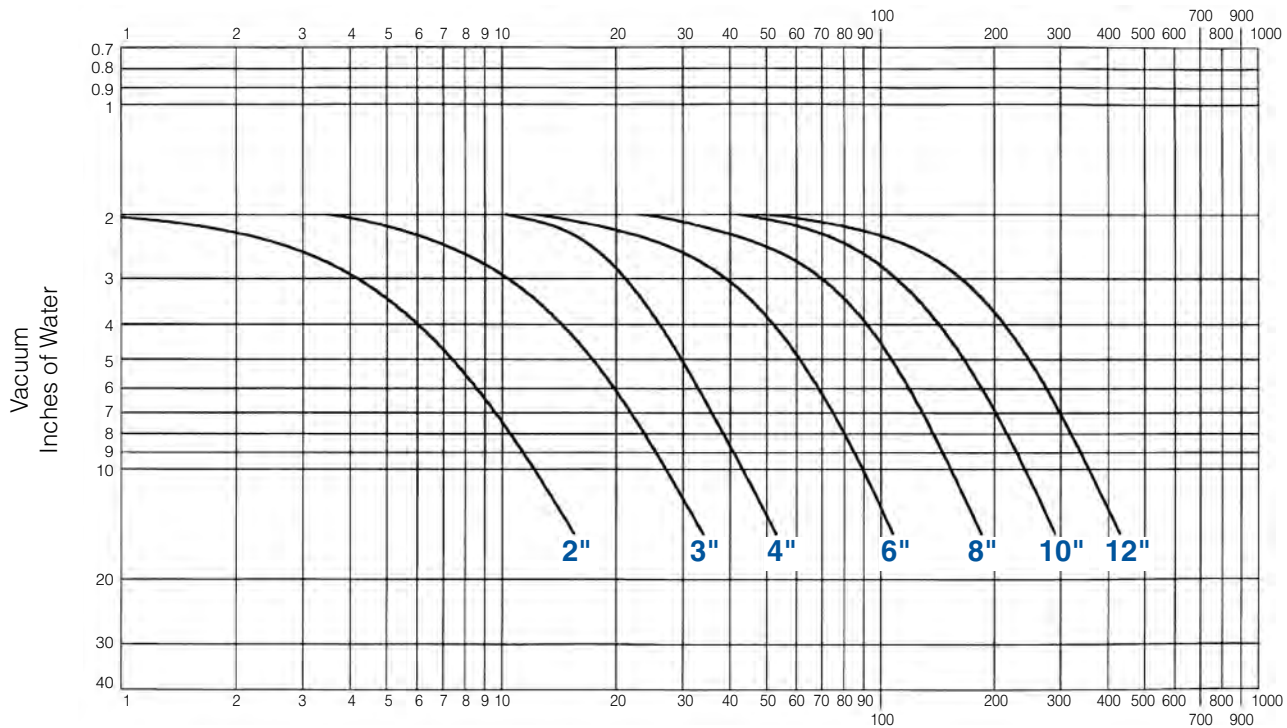

Thousands of Cubic Feet/Hour at 60°F and 14.7 psia, Air Flow (SCFH)

Flow Curves for 2020B Series, Set at 4 inches of Water

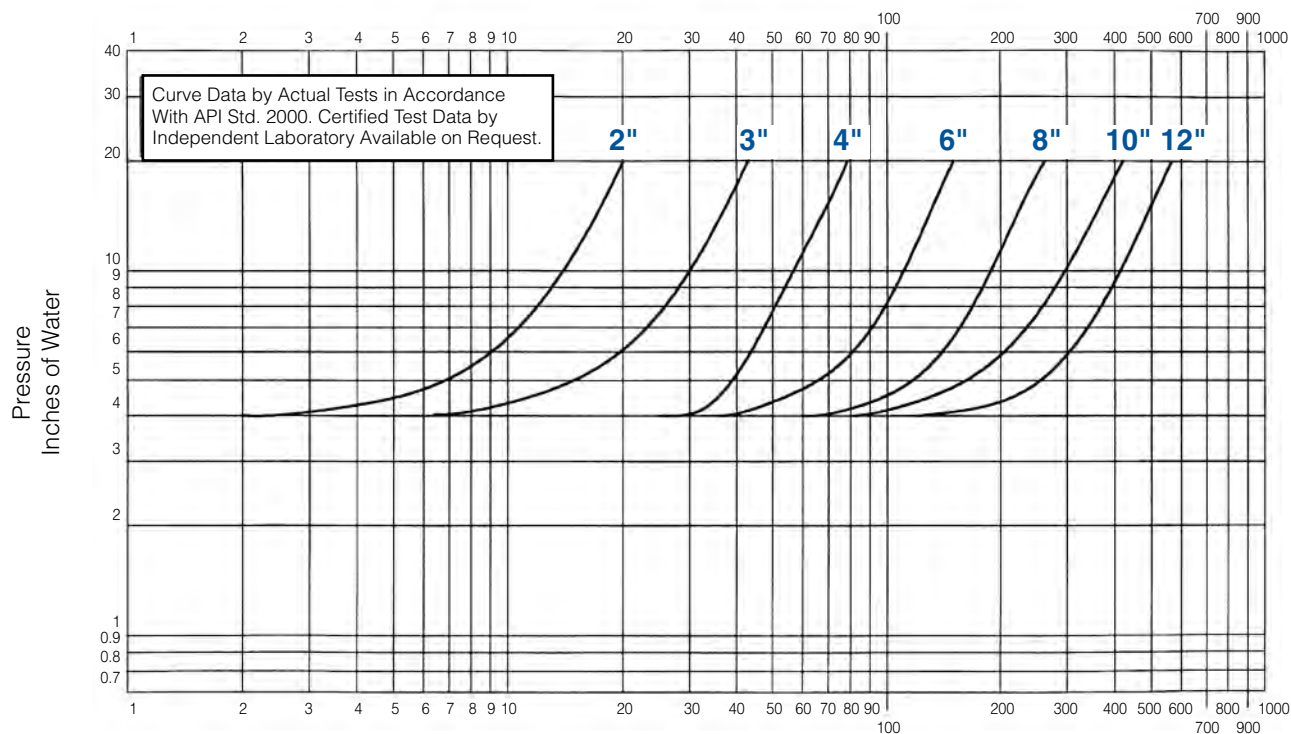

Thousands of Cubic Feet/Hour at 60°F and 14.7 psia, Air Flow (SCFH)

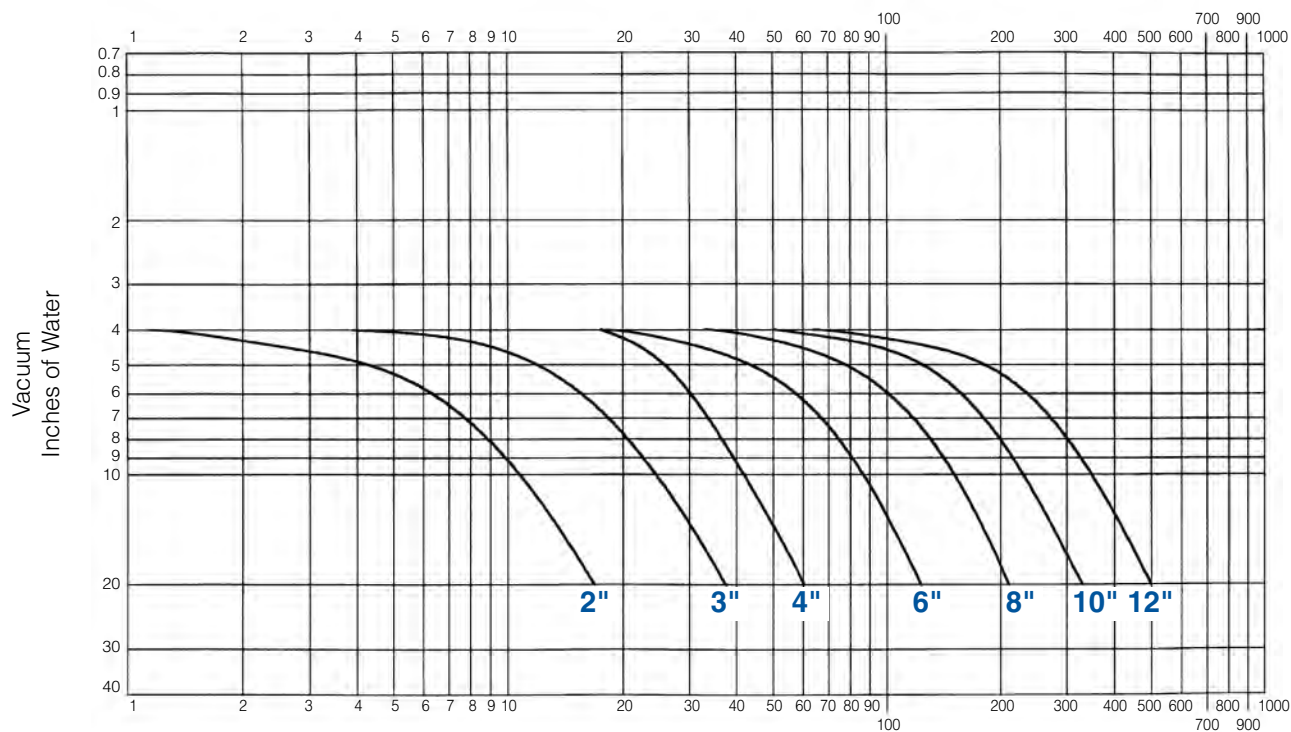

Thousands of Cubic Feet/Hour at 60°F and 14.7 psia, Air Flow (SCFH)

Flow Curves for 2020B Series, Set at 6 inches of Water

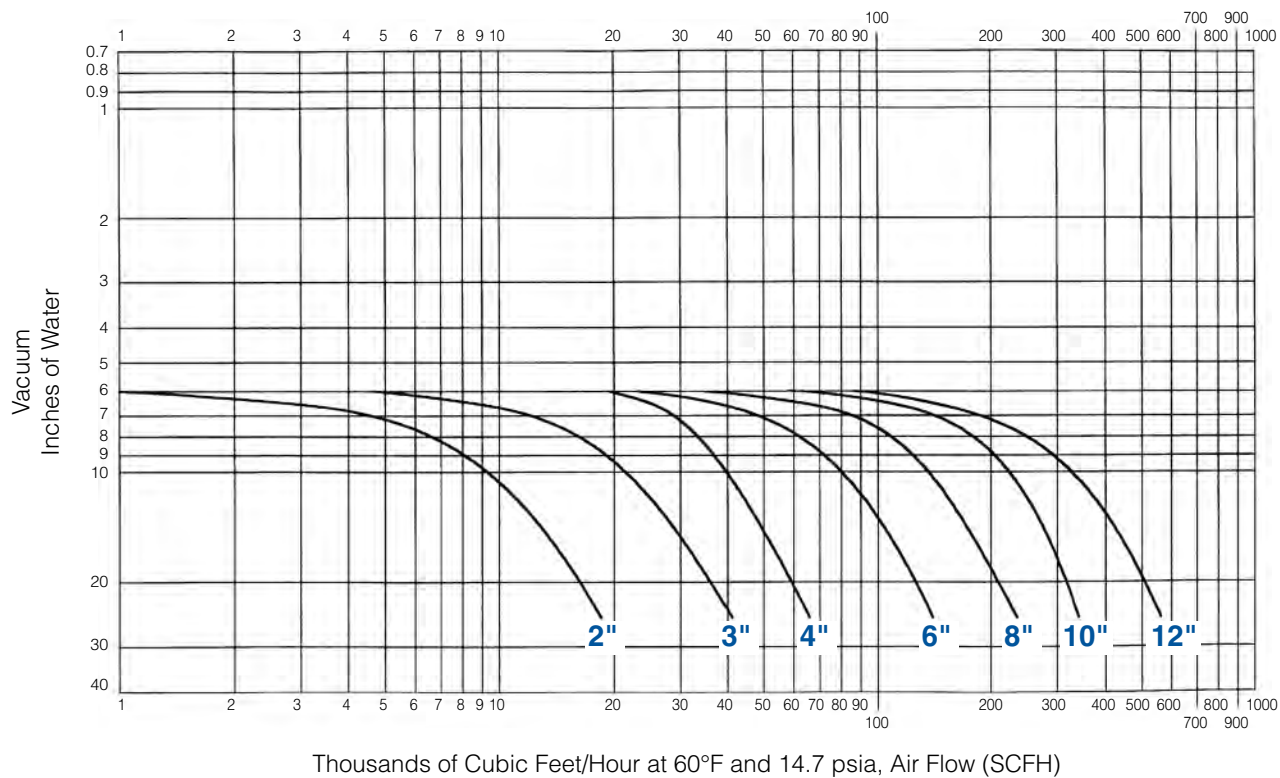
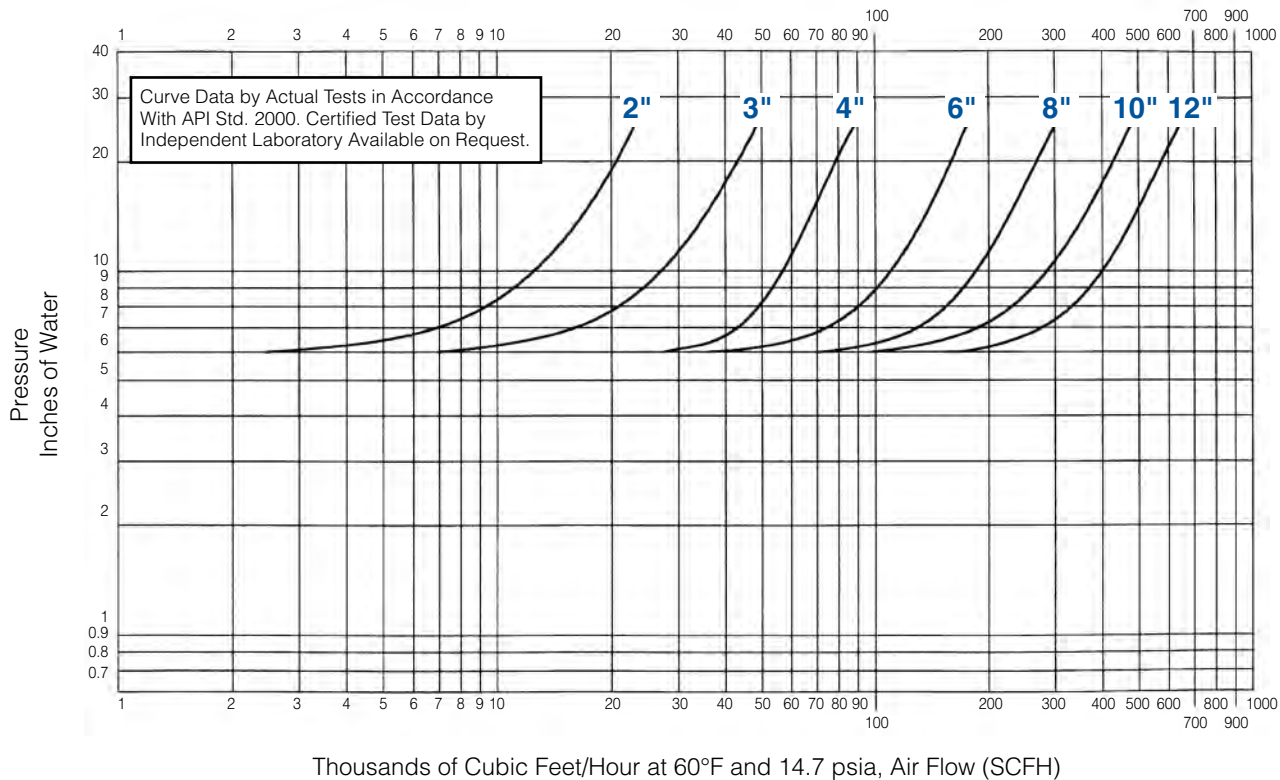

Flow Curves for 2020B Series, Set at 8 inches of Water

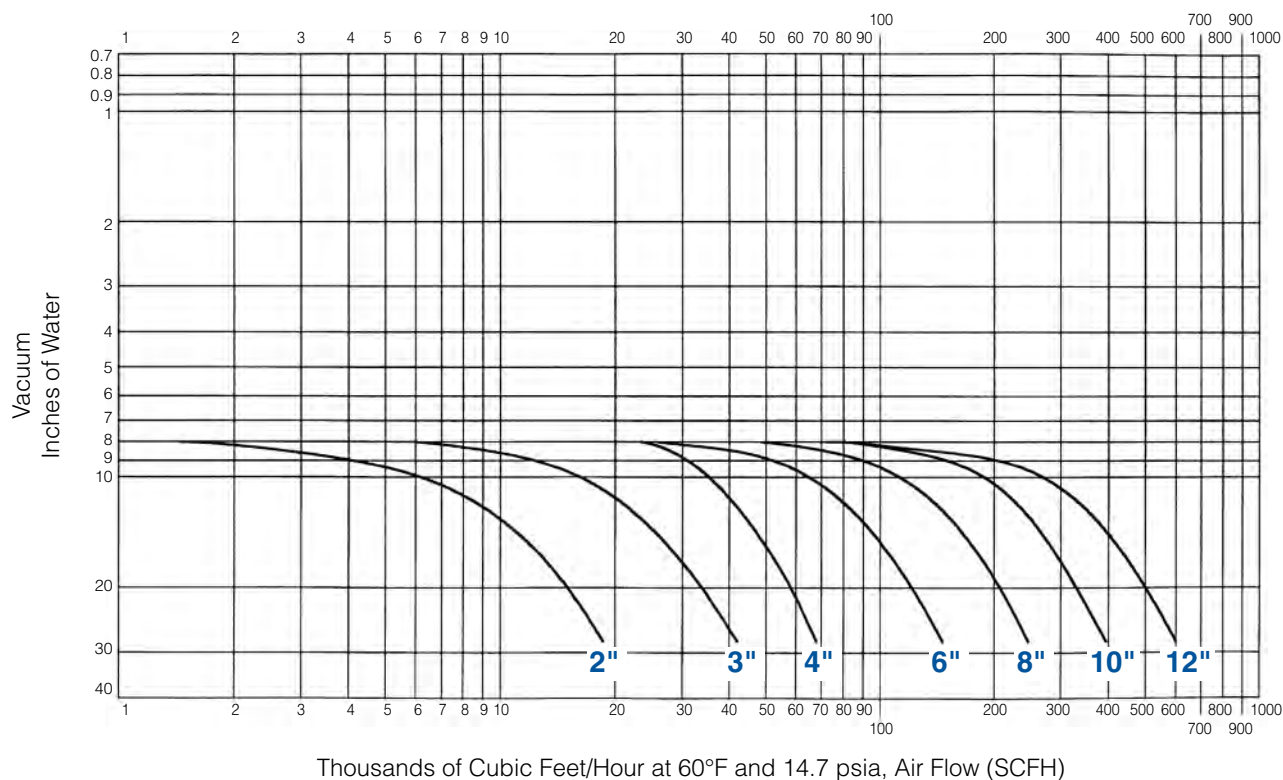
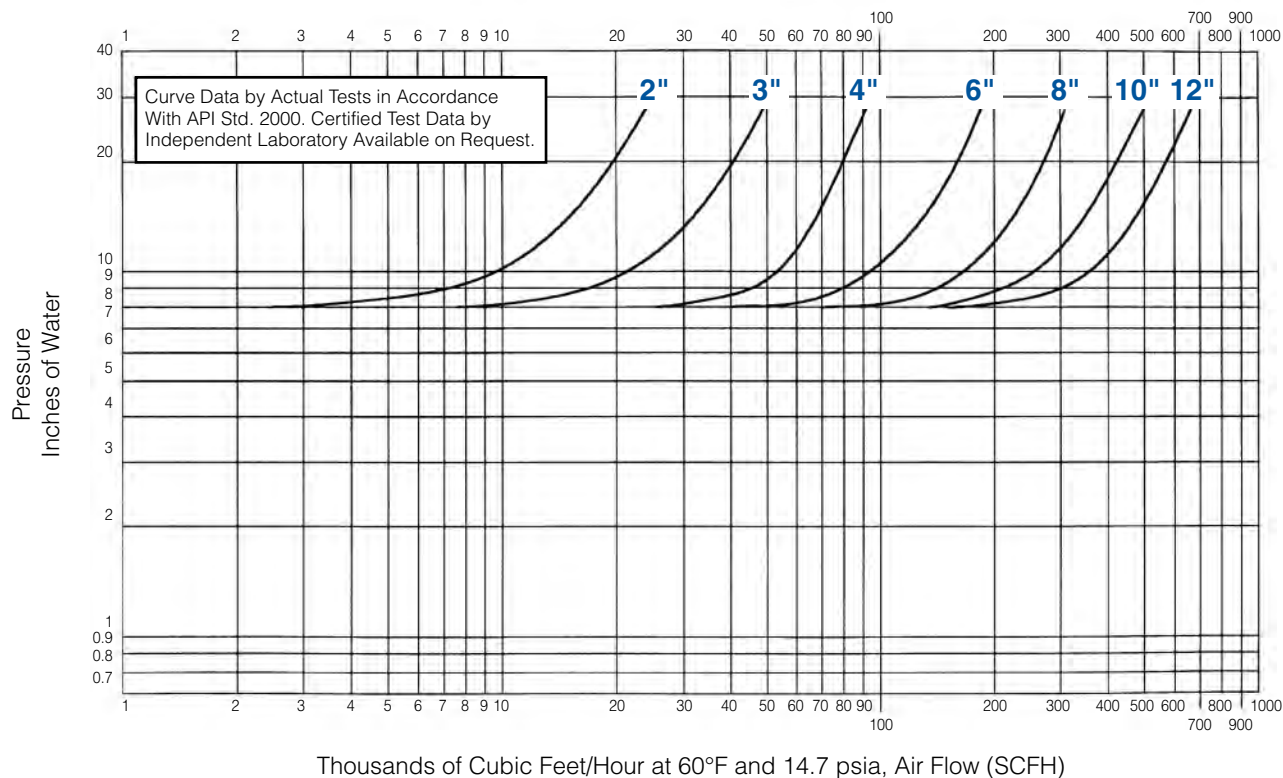

Flow Curves for 2020B Series, Set at 10 inches of Water

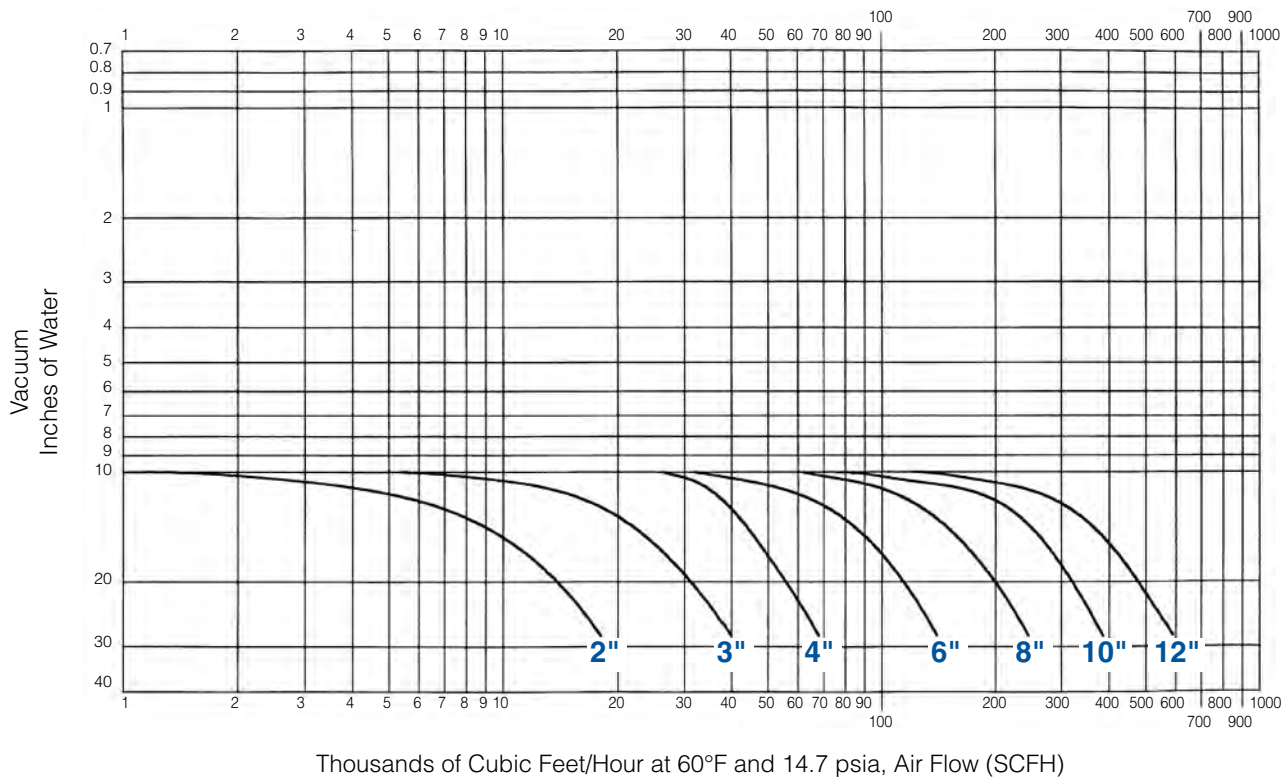
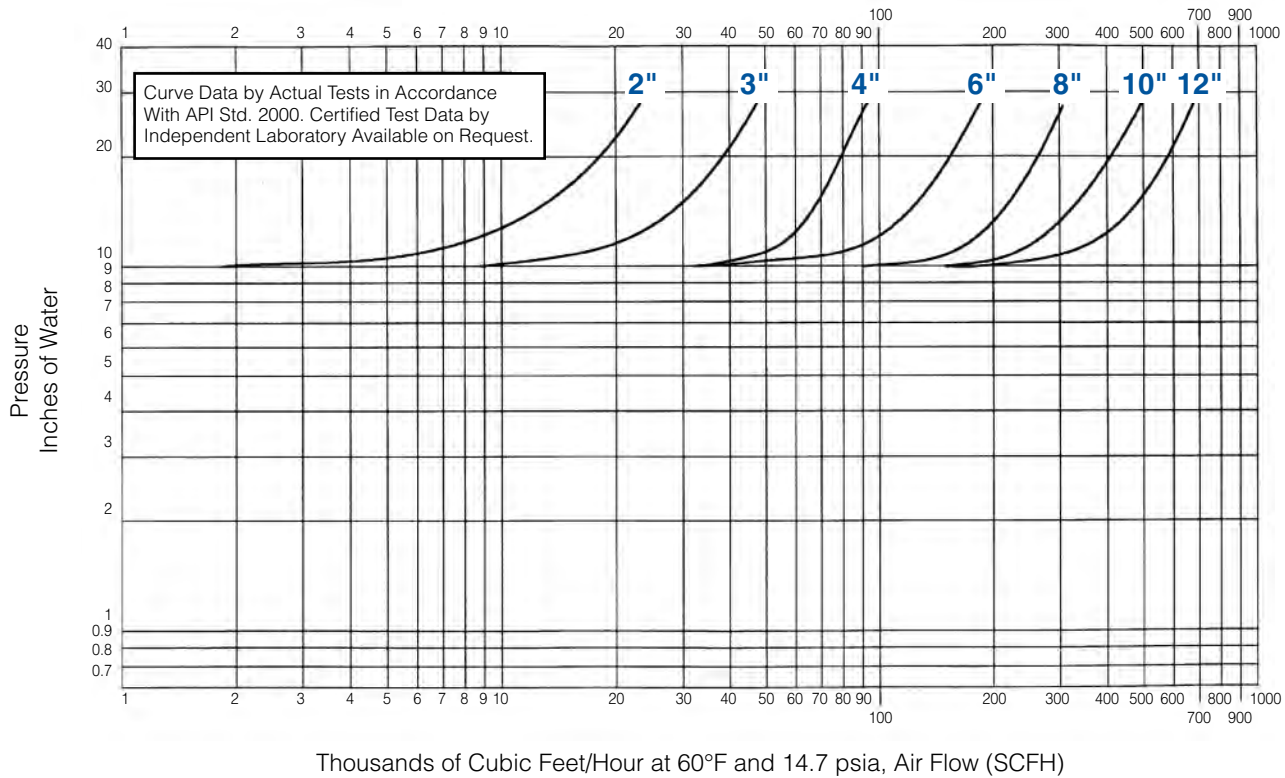

Dimensions, in. [mm]

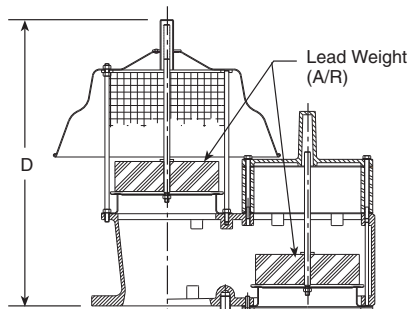
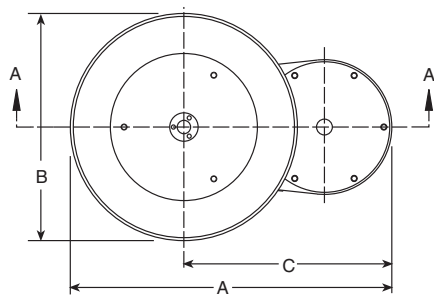

Section A-A

2010B and 2011B							
Size Code	2	3	4	6	8	0	1
Nominal Pipe Size	2 [50]	3 [80]	4 [100]	6 [150]	8 [200]	10 [250]	12 [300]
A	14 ¹ / ₈ [359]	17 ⁹ / ₁₆ [446]	19 ¹ / ₈ [486]	24 [610]	29 ⁷ / ₈ [759]	38 ⁷ / ₁₆ [976]	46 ⁵ / ₈ [1184]
B	8 ¹ / ₂ [216]	10 ³ / ₄ [273]	13 ³ / ₈ [340]	17 [432]	20 ⁵ / ₈ [524]	27 [686]	34 [864]
C	9 ⁷ / ₈ [251]	12 ¹ / ₄ [311]	12 ⁷ / ₁₆ [316]	15 ¹ / ₂ [394]	19 ⁹ / ₁₆ [497]	24 ¹⁵ / ₁₆ [633]	29 ³ / ₈ [746]
D	10 ⁷ / ₁₆	12 ⁵ / ₁₆	14 ¹ / ₂	18 ⁹ / ₁₆	21 ⁵ / ₈	27 ⁷ / ₁₆	31 ⁷ / ₈
Low Set	[265]	[313]	[368]	[462]	[549]	[697]	[810]
D	13 ⁵ / ₁₆	15 ¹ / ₄	16 ⁵ / ₈	21 ¹ / ₂	24 ³ / ₄	29 ⁷ / ₁₆	31 ⁷ / ₈
High Set	[338]	[387]	[422]	[546]	[629]	[748]	[810]

Figure shown is for high set option.

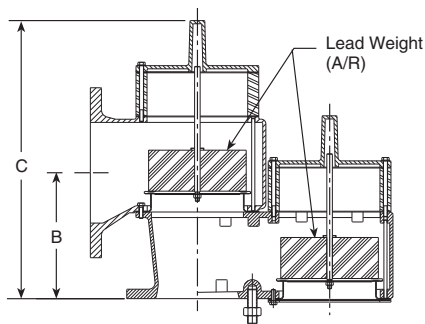
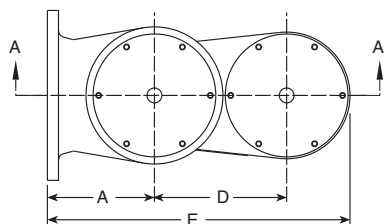

Section A-A

2020B and 2021B							
Size Code	2	3	4	6	8	0	1
Nominal Pipe Size	2 x 3 [50 x 80]	3 x 4 [80 x 100]	4 x 6 [100 x 150]	6 x 8 [150 x 200]	8 x 10 [200 x 250]	10 x 12 [250 x 300]	12 x 14 [300 x 350]
A	4 ¹⁵ / ₁₆ [125]	6 ³ / ₈ [162]	8 [203]	8 ⁹ / ₁₆ [217]	11 ³ / ₁₆ [284]	13 ³ / ₈ [346]	15 ³ / ₈ [391]
B	5 ¹ / ₄ [133]	5 ⁷ / ₈ [149]	6 ¹³ / ₁₆ [173]	10 [254]	12 ¹ / ₈ [308]	16 ¹ / ₈ [410]	18 ³ / ₄ [476]
C	9 ¹ / ₁₆ [230]	10 ³ / ₄ [273]	12 ³ / ₄ [324]	18 ³ / ₄ [476]	22 ¹ / ₈ [562]	27 ⁹ / ₁₆ [700]	32 [813]
Low Set	[230]	[273]	[324]	[476]	[562]	[700]	[813]
C	13 ¹ / ₂	15 ¹ / ₂	16 ¹³ / ₁₆	22	24 ¹ / ₂	29 ¹ / ₄	32
High Set	[343]	[394]	[427]	[559]	[622]	[743]	[813]
D	6 ³ / ₄ [171]	8 ³ / ₈ [213]	8 ⁷ / ₁₆ [214]	10 ¹ / ₂ [267]	13 ³ / ₈ [333]	16 ⁷ / ₈ [429]	19 ³ / ₄ [502]
E	14 ³ / ₄ [375]	18 ⁹ / ₁₆ [471]	20 ⁷ / ₁₆ [519]	24 ¹ / ₄ [616]	30 ³ / ₄ [781]	38 ⁹ / ₁₆ [979]	44 ¹¹ / ₁₆ [1135]

Figure shown is for high set option.

Dimensions are for preliminary general information and should not be used for construction purposes. Certified dimensional drawings are available upon request.

Ordering Information

Code **Description**
 20 Air Cushion Pressure/Vacuum Relief Valve

Code **Model**
 1 Vent-to-Atmosphere
 2 Pipe-Away

Code **Configuration**
 0B Standard
 1B All Weather Type (-25°F to 200°F)

Code **Size**
 2 2" (2" x 3")
 3 3" (3" x 4")
 4 4" (4" x 6")
 6 6" (6" x 8")
 8 8" (8" x 10")
 0 10" (10" x 12")
 1 12" (12" x 14")

Code **Body/Trim Material**
 1 Aluminum/Aluminum (-20°F to 250°F)
 2 Aluminum/316 Stainless Steel (-20°F to 250°F)
 3 Carbon Steel/316 Stainless Steel (-20°F to 350°F)
 4 316 Stainless Steel/316 Stainless Steel (-65°F to 350°F)
 5 Ductile Iron/316 Stainless Steel (2 to 8 Inch only) (-20°F to 325°F)

Code **Insert Material**
 T Teflon® (-65°F to 400°F)
 B BUNA-N (-40°F to 250°F)
 V Viton® (-15°F to 400°F)

Code **Flange Connection**
 FF 125# ANSI/ASA Flat Face Flange Drilling with Fractional Studs
 MF 125# ANSI/ASA Flat Face Flange Drilling with Metric Studs
 FR 150# ANSI/ASA Raised Face Flange Drilling with Fractional Studs
 (not available on Aluminum)
 MR 150# ANSI/ASA Raised Face Flange Drilling with Metric Studs
 (not available on Aluminum)
 DF DIN Flat Face Flange Drilling
 DR DIN Raised Face Flange Drilling (not available on Aluminum)

Code **Gasket/O-ring and Retainer/Screen Material**
 OP Standard Fiber/BUNA-N and Plastic (-40°F to 250°F)
 OS Standard Fiber/BUNA-N and Stainless Steel (-40°F to 250°F)
 TP Teflon® and Plastic (-65°F to 250°F)
 TS Teflon® and Stainless Steel (-65°F to 350°F)
 BP BUNA-N and Plastic (-40°F to 250°F)
 BS BUNA-N and Stainless Steel (-40°F to 250°F)
 VP Viton® and Plastic (-15°F to 250°F)
 VS Viton® and Stainless Steel (-15°F to 350°F)

Code **Pressure Setting Range** (see table, page 4)
 02 Low Setting
 04 High Setting

Code **Vacuum Setting Range** (see table, page 4)
 02 Low Setting
 04 High Setting

20 1 0B 1 2 T FF 0P 02 02 (Example)

Example: 12" size Aluminum body/316SS trim, Teflon® insert, 125 FF Flanges, Standard Fiber/BUNA-N gaskets, low set pressure and vacuum, temperature range: -20°F to 250°F.

Tyco Flow Control (TFC) provides the information herein in good faith but makes no representation as to its comprehensiveness or accuracy. This data sheet is intended only as a guide to TFC products and services. Individuals using this data sheet must exercise their independent judgment in evaluating product selection and determining product appropriateness for their particular purpose and system requirements. TFC MAKES NO REPRESENTATIONS OR WARRANTIES, EITHER EXPRESS OR IMPLIED, INCLUDING WITHOUT LIMITATION ANY WARRANTIES OF MERCHANTABILITY OR FITNESS FOR A PARTICULAR PURPOSE WITH RESPECT TO THE INFORMATION SET FORTH HEREIN OR THE PRODUCT(S) TO WHICH THE INFORMATION REFERS. ACCORDINGLY, TFC WILL NOT BE RESPONSIBLE FOR DAMAGES (OF ANY KIND OR NATURE, INCLUDING INCIDENTAL, DIRECT, INDIRECT, OR CONSEQUENTIAL DAMAGES) RESULTING FROM THE USE OF OR RELIANCE UPON THIS INFORMATION. Patents and Patents Pending in the U.S. and foreign countries. Tyco reserves the right to change product designs and specifications without notice. All registered trademarks are the property of their respective owners. Printed in the USA.