



The 5400A Series, Group “D”, end-of-line flame arrester is designed to prevent the propagation of flames into a storage vessel.

Introduction

Varec Flame Arresters have been the industry standard for many years. They are used worldwide throughout the petroleum, petrochemical, chemical, pulp and paper, food and beverage and other industries where flame propagation is a potential problem. Varec's success in this area is based on its high standards for product design and manufacturing.

The 5400A Series utilizes two principles to stop the propagation of flame from external sources. The first method is dissipation of heat. The temperature of the flame front is reduced below the flash point of the vapor by the absorption of heat through the surface of the bank assembly.

The second method concerns the quenching diameter of Class “D” vapors. The space between the bank assembly crimps is smaller than the diameter required to pass a flame of a Class “D” gas.

These units are generally used in conjunction with low flash point liquids and flammable gases or vapors. They should be installed vertically on tank vent systems or in piping headers up to a maximum of 10 pipe diameters upstream of the ignition source, when used in accordance with FM Approval, or 15 feet when used in accordance with UL Approval.

For distances or gas classifications outside these limits, the detonation arrester should be used. Proper application of flame arresters is crucial for plant safety. Varec applications engineers or factory trained representatives can assist you with your specific applications.

Features

The net free area through all Varec Flame Arrester banks is three to four times the unit pipe size. This design reduces surface friction, therefore, optimizing flow capacity and minimizing pressure drop. The large surface area of the bank also improves heat dissipation.



Varec 5400A Series Flame Arresters are designed with a spiral wound and crimped bank element.

Maintenance of the bank assembly is relatively simple:

- The tie rod bolts are removed and the remaining jackscrews expanded. This extends the end housings allowing the bank assembly to be easily removed.
- A handle is provided for easy handling.
- The bank element can be quickly inspected or cleaned and replaced between the end housings.

Technical Data

- Three to four times net free area through bank.
- UL and FM approved.
- Rugged construction for extended life.
- Unitized design with jackscrews for easy inspection and maintenance.
- Broad range of materials available.

Sizes

2", 3", 4", 6", 8", 10" and 12"

Specifications

Connections

- Flange drilling per ANSI Class 150
- Flat face flange – aluminum
- Raised face flange – CS, Ductile iron and 316 SS

Materials

Housing:

- Heavy wall, 356 HT low copper aluminum, standard
- CS, Ductile iron or 316 SS, optional

Bank Assembly:

- Low copper aluminum core housing and element, standard
- Low copper aluminum core housing with 316 SS element, optional
- All 316 SS core housing and element, optional

Pressure

Pressure Rating:
Leak proof to 10 psi [69.0 kPa]

Pressure Drop:
Should not exceed 1 psi [6.9 kPa]

Location¹

Within 15 feet [4.6 m] upstream of flame source when used in accordance with UL Listing, or 10 pipe diameters when used in accordance with FM Approval.

Configuration

- Net Free Area: Three to four times the corresponding size standard pipe.
- Bank Assembly: Spiral wound and crimped element with core housing and integral handle.

Approvals

- UL (Underwriters Laboratories) listed in all aluminum construction in 2", 3", 4"¹
- FM (Factory Mutual) All sizes, all materials¹

Note:

1. For use on hydrocarbon storage tanks, installed NOT MORE THAN 15 FEET from the open end of the vent pipe when used in accordance with UL Listing or 10 pipe diameters when used in accordance with FM Approval. These test conditions may not represent the actual service conditions of piping system design. It is recommended that the arrester be independently tested under actual service conditions before installation.

Dimensions, inches and pounds [millimeters and kilograms]

Size Code	2	3	4	6	8	0	1
Nominal Pipe Size	2	3	4	6	8	10	12
	[50]	[80]	[100]	[150]	[200]	[250]	[300]
L Length	14 ¹ / ₂ [368]	16 ¹ / ₂ [419]	20 ⁵ / ₁₆ [516]	21 ³ / ₄ [552]	25 ³ / ₄ [654]	30 ¹ / ₂ [775]	34 ⁹ / ₁₆ [878]
H Height	9 ¹ / ₂ [241]	11 ¹ / ₂ [292]	13 ¹ / ₄ [337]	17 ³ / ₄ [451]	22 [559]	24 [610]	30 [762]
W Width	9 ¹ / ₈ [232]	11 ³ / ₁₆ [284]	15 ⁵ / ₈ [397]	19 [483]	23 ¹ / ₄ [591]	25 ¹ / ₄ [641]	31 ¹ / ₄ [787]
Shipping Weight	25 [11]	35 [16]	45 [20]	90 [41]	140 [64]	210 [95]	325 [148]

Notes:

Flange drilling per ANSI Class 150

Flat face flange – aluminum

Raised face flange – CS, Ductile iron and 316 SS

Installation, mounting arrangement and dimensions are preliminary information not to be used for construction. Certified drawings are available upon request.

Ordering Information

Model

5400A Flame Arrester (vertical installation only)

Size

2	2"
3	3"
4	4"
6	6"
8	8"
0	10"
1	12"

Materials: Housing/Core/Element

1	Aluminum/Aluminum/Aluminum
2	Aluminum/316 SS/316 SS
3	Carbon Steel/316 SS/316 SS
5	Ductile Iron/316 SS/316 SS
6	316 SS/316 SS/316 SS

5400A 2 1 (Example)

Example: 2" Flame Arrester with aluminum housing, aluminum core housing and element

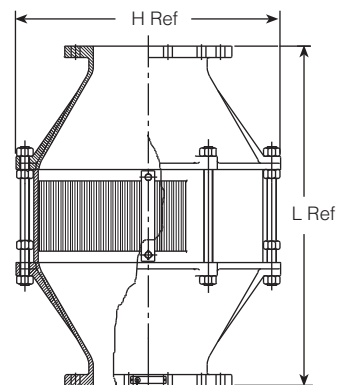
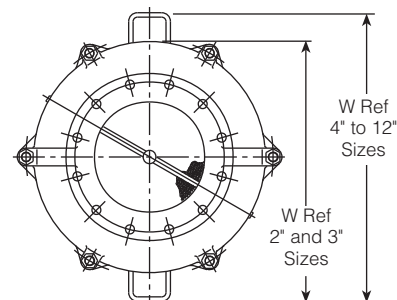

Flow Curves

5400A Series Flame Arrester

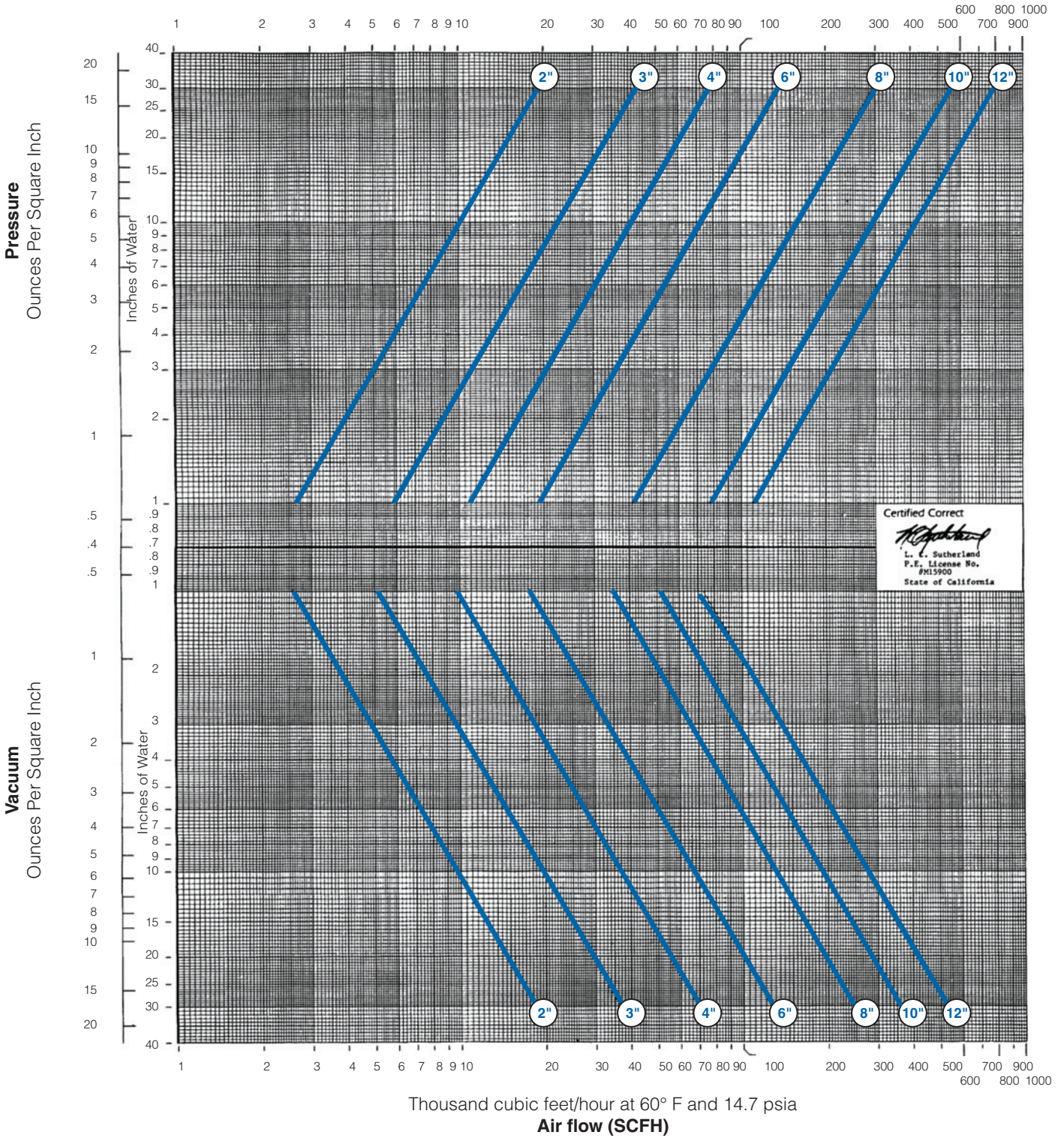

Flow Curves

2010B Series Relief Valve with 5400A Series Flame Arrester Set at 0.865 Inches of Water Pressure and Vacuum

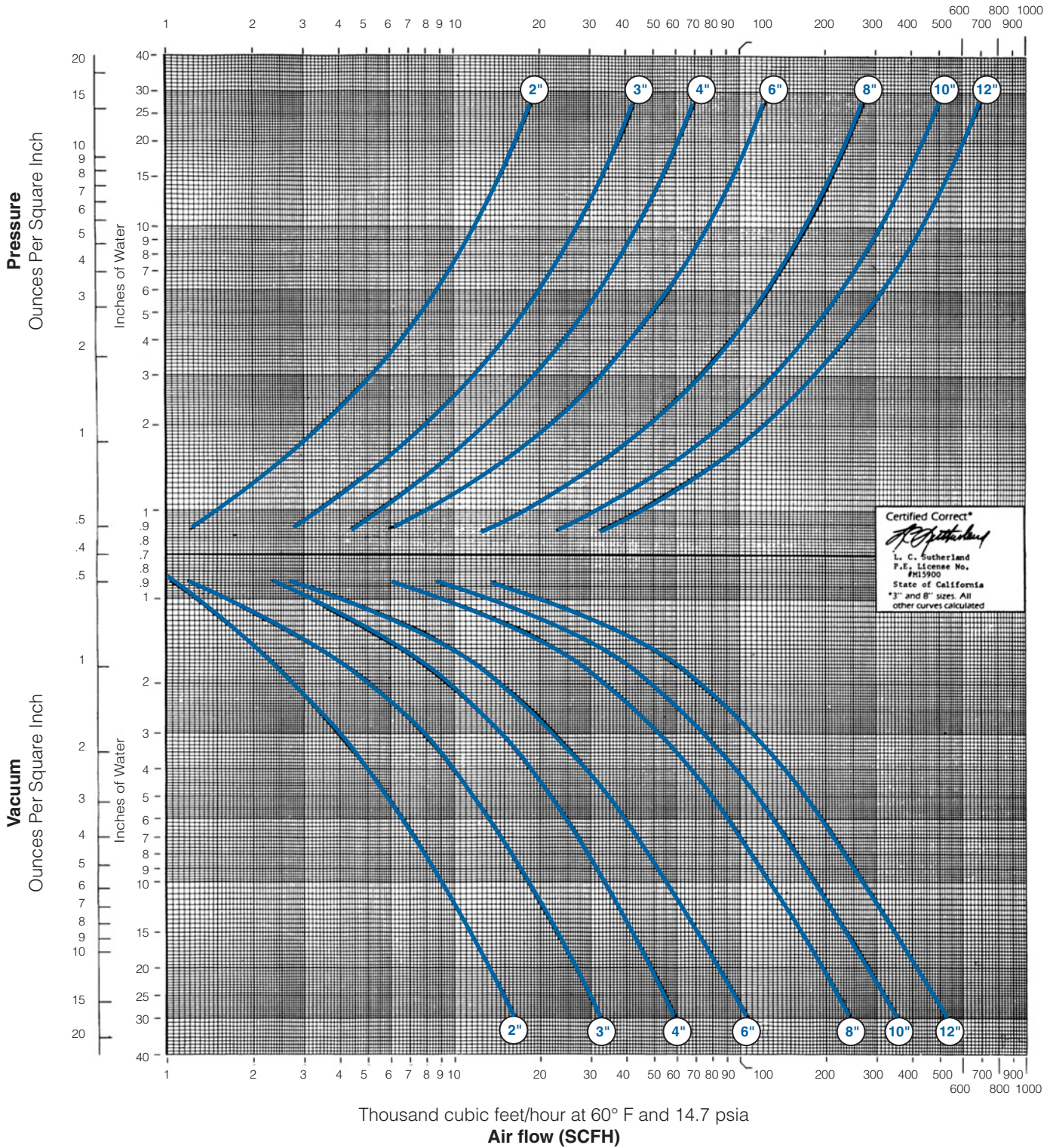

Tyco Flow Control (TFC) provides the information herein in good faith but makes no representation as to its comprehensiveness or accuracy. This data sheet is intended only as a guide to TFC products and services. Individuals using this data sheet must exercise their independent judgment in evaluating product selection and determining product appropriateness for their particular purpose and system requirements. TFC MAKES NO REPRESENTATIONS OR WARRANTIES, EITHER EXPRESS OR IMPLIED, INCLUDING WITHOUT LIMITATION ANY WARRANTIES OF MERCHANTABILITY OR FITNESS FOR A PARTICULAR PURPOSE WITH RESPECT TO THE INFORMATION SET FORTH HEREIN OR THE PRODUCT(S) TO WHICH THE INFORMATION REFERS. ACCORDINGLY, TFC WILL NOT BE RESPONSIBLE FOR DAMAGES (OF ANY KIND OR NATURE, INCLUDING INCIDENTAL, DIRECT, INDIRECT, OR CONSEQUENTIAL DAMAGES) RESULTING FROM THE USE OF OR RELIANCE UPON THIS INFORMATION. Patents and Patents Pending in the U.S. and foreign countries. Tyco reserves the right to change product designs and specifications without notice. All registered trademarks are the property of their respective owners. Printed in the USA.