



The 5910B/5920B Series Relief Valve and Flame Arrester is a combination of the 2010B/2020B Series Pressure and Vacuum Relief Valve and the 5400A Series Flame Arrester.

The Varec 5910B/5920B Series Relief Valve and Flame Arrester is a combination of the Varec 2010B/2020B Series Pressure and Vacuum Relief Valve and the Varec 5400A Series Flame Arrester. This unit combines the high flow capacity of the Relief Valve with the easy-to-maintain flame arrester for maximum protection and reliable operation.

Features

- Oversized pressure and vacuum ports.
- Oversized flame arrester bank assembly for minimum pressure drop.
- Replaceable and interchangeable pressure and vacuum seat rings.
- “All-weather” coating option available for valve seats and guides.
- Vent to atmosphere or pipe-away model.

Benefits

- Large flow capacity allows use of smaller size.
- Easy maintenance.
- Valve will operate at temperatures to -25°F [-32°C].
- Application flexibility for either weather or emissions considerations.
- Reduced number of spare parts required.



Specifications

Introduction

The Varec 5910B/5920B Series Pressure and Vacuum Relief Valve with Flame Arrester is installed on above ground storage tanks containing potentially flammable liquids and vapors. The relief valve protects the tank from excessive pressure and vacuum. It maintains system operating pressure so vapor is not routinely vented to the atmosphere. The flame arrester protects the tank from accidental ignition of vapor within the tank. It is designed to stop the propagation of flame from external sources. For further information on these devices, see the product data sheet for Varec 2010B/2020B and 5400A.

A variety of materials are available to suit climate conditions. The standard aluminum construction is suitable for moderate climates. In extreme hot, humid or freezing weather, the "All-weather" 5911B Series is recommended. This design incorporates added features that reduce potential malfunctions from these extreme conditions.

The 5920B Series provides for further protection from cold climates and provides a means to route vented vapor instead of venting to atmosphere. This unit incorporates an enclosed pressure port on the relief valve. It is especially suited for field installation of insulation jackets or insulated shelters. The 5921B Series includes the pipe-away outlet and the "All-weather" features for maximum cold weather protection.

If H₂S corrosion is a concern, supplying the relief valve with 316 SS trim is an option. The flame arrester bank is also available in 316 SS material.

Operation

Whenever the tank pressure or vacuum exceeds the setting, the pallet lifts. Only excess pressure is vented to the atmosphere. Air is drawn into the tank only to relieve an excess vacuum condition. The valve remains closed when the vapor space remains within normal operating pressure.

The valve pallets are deadweight loaded with a field adjustable pressure setting range. Side and center pallet guides are incorporated for stability. "Air cushion" Teflon® seat inserts ensure a tighter seal. Removable seats can be easily replaced.

The case outlet adapter on the pipe-away model is one pipe size larger than the valve inlet flange to optimize flow capacities.

The "All-weather" models feature a special non-frosting and icing-resistant coating. This coating is applied to the pallet perimeter and stem, guide posts, and seat ring tip. This feature provides additional protection against pallets freezing closed.

The flame arrester helps stop the propagation of a flame by absorbing and dissipating heat through the surface area of the bank. Heat is absorbed as ignited gas attempts to pass through the small passages within the bank assembly. This action lowers the temperature of the gas below its ignition point and quenches the flame.

The net free area through the flame arrester bank is three to four times the unit pipe size. This design provides increased flow capacity with minimal pressure drop. The bank assembly can be easily inspected and cleaned to remove any dirt or residue build-up.

Specifications

Sizes

- 5910B: 2", 3", 4", 6", 8", 10" and 12"
- 5920B: 2" x 3", 3" x 4", 4" x 6", 6" x 8", 8" x 10", 10" x 12", and 12" x 14"

Connections

- Aluminum – Drilled to ANSI 125 Flat Faced flange connection.
- Steel – Drilled to ANSI 150 Raised Face flange connection.

Special drilling requirements to DIN, JPI or JIS standards are available upon request. Consult your sales representative for further details.

Flow Data

- Consult your sales representative for flow data information. Valve sizing programs are available upon request.

Settings

- Pressure and Vacuum Settings: Available up to 1 psig.

Standard Specification

Model 5400A Flame Arrester UL (Underwriters Laboratories) listed in all aluminum construction in 2", 3" and 4" sizes. FM approved all sizes and all materials.

Applications

The arresters are designed to stop the propagation of flame (Group "D" gases) from external sources. They can be mounted up to 15 feet upstream of the ignition source in accordance with UL approval, or 10 pipe diameters in accordance with FM approval requirements.

The 5910B and 5920B Series are for vertical installations.

Dimensions

5910B Series

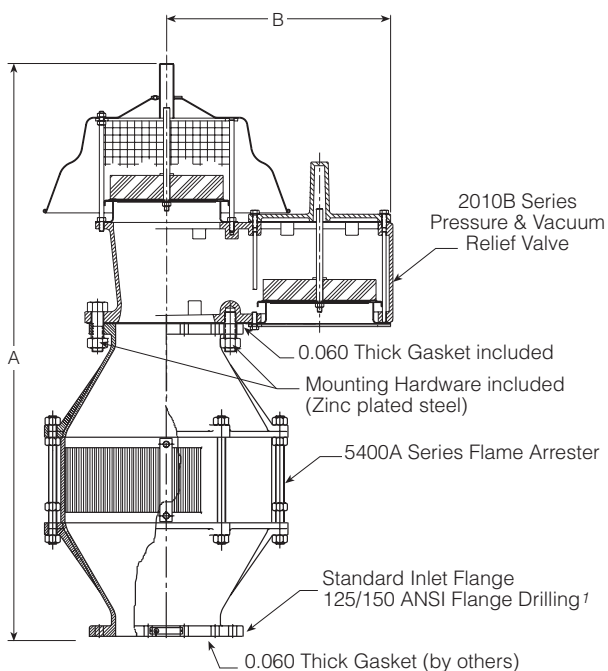

5920B Series

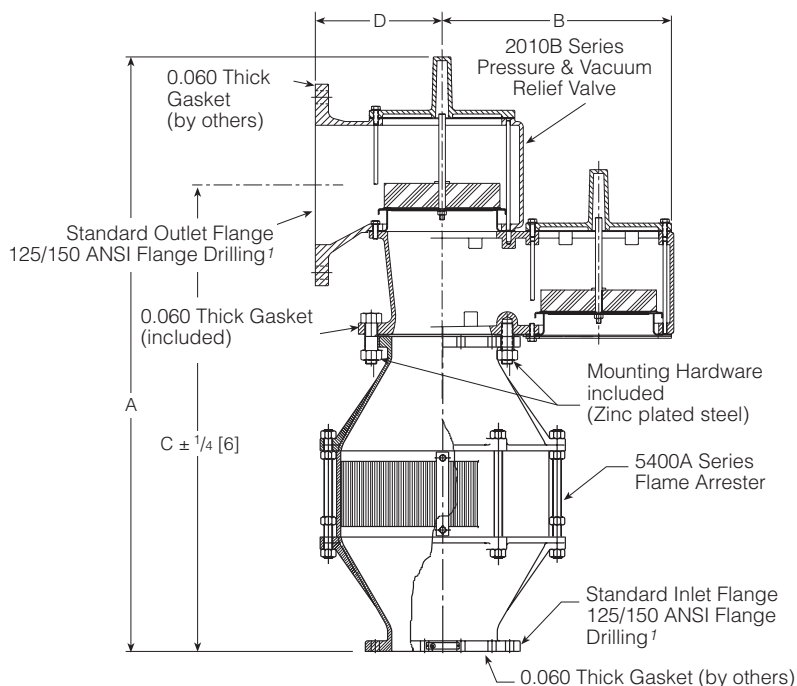

Note:

- Aluminum bodies Flat Face only.
Stainless and carbon steel Raised Face only.

5910B Dimensions, inches [mm]

| Size | A | B |
|------|---------------|---------------|
| 2 | 25 [635] | 97/8 [251] |
| 3 | 287/8 [733] | 121/4 [311] |
| 4 | 347/8 [886] | 127/16 [316] |
| 6 | 40 [1016] | 151/2 [394] |
| 8 | 477/16 [1205] | 199/16 [497] |
| 10 | 58 [1473] | 2415/16 [633] |
| 12 | 661/2 [1689] | 293/8 [746] |

5920B Dimensions, inches [mm]

| Size | | A | B | C | D |
|-------|--------|----------------|---------------|----------------|--------------|
| Inlet | Outlet | | | | |
| 2" | 3" | 235/8 [600] | 97/8 [251] | 1913/16 [503] | 415/16 [125] |
| 3" | 4" | 275/16 [694] | 121/4 [311] | 227/16 [570] | 63/8 [162] |
| 4" | 6" | 331/8 [841] | 127/16 [316] | 273/16 [691] | 8 [203] |
| 6" | 8" | 409/16 [1030] | 151/2 [394] | 3113/16 [808] | 83/4 [222] |
| 8" | 10" | 4715/16 [1218] | 199/16 [497] | 3715/16 [964] | 113/16 [284] |
| 10" | 12" | 581/8 [1476] | 2415/16 [633] | 4611/16 [1186] | 135/8 [346] |
| 12" | 14" | 665/8 [1692] | 293/8 [746] | 533/8 [1356] | 153/8 [391] |

Ordering Information

Model Description

59 Relief Valve and Flame Arrester

| Code | Configuration |
|------|--------------------|
| 1 | Vent to Atmosphere |
| 2 | Pipe-Away |

| Code | Model |
|------|--------------------|
| 0B | Air Cushion Type |
| 1B | "All Weather" Type |

| Code | Size (Pipe-Away Option) |
|------|-------------------------|
| 2 | 2" (x 3") |
| 3 | 3" (x 4") |
| 4 | 4" (x 6") |
| 6 | 6" (x 8") |
| 8 | 8" (x 10") |
| 0 | 10" (x 12") |
| 1 | 12" (x 14") |

Code Relief Valve and Flame Arrester Material (must specify one)

| | |
|---|----------------------------------------------------------------------------------------------------------------------------------------------------------------------------------------|
| 1 | All-Aluminum Construction Aluminum body and trim on valve, Aluminum housing, flame bank, ANSI 125 FF flange connections |
| 2 | Aluminum/Stainless Steel Construction Aluminum body and Stainless Steel trim on valve; Aluminum housing with Stainless Steel flame bank, ANSI 125 FF flange connections |
| 3 | Carbon Steel/Stainless Steel Construction Carbon Steel body and Stainless Steel trim on valve; Carbon Steel housing with Stainless Steel flame bank, ANSI 150 RF flange connections |
| 4 | All-Stainless Steel Construction 316 SS body and trim on valve, Stainless Steel housing with Stainless Steel flame bank, ANSI 150 RF flange connections |

59 1 0B 8 2 (Example)

Example: Pressure/Vacuum Relief Valve with Flame Arrester, vent to atmosphere, air-cushion type, 8" size, aluminum body and stainless steel trim on valve; aluminum housing and extensible bank, rectangular stainless steel sheets on flame arrester. Specify pressure and vacuum settings.

5910B Shipping Weights, lbs. (kg)

| Size | Material Code | | | |
|------|---------------|-----------|------------|------------|
| | 1 | 2 | 3 | 4 |
| 2" | 52 (24) | 72 (33) | 107 (49) | 107 (49) |
| 3" | 78 (35) | 108 (49) | 158 (72) | 158 (72) |
| 4" | 112 (51) | 157 (71) | 247 (112) | 247 (112) |
| 6" | 177 (80) | 232 (105) | 367 (166) | 367 (166) |
| 8" | 242 (110) | 327 (148) | 602 (273) | 602 (273) |
| 10" | 418 (190) | 553 (251) | 933 (423) | 933 (423) |
| 12" | 637 (289) | 837 (380) | 1227 (557) | 1227 (557) |

5920B Shipping Weights, lbs. (kg)

| Size | Material Code | | | |
|------|---------------|-----------|------------|------------|
| | 1 | 2 | 3 | 4 |
| 2" | 62 (28) | 82 (37) | 136 (62) | 136 (62) |
| 3" | 93 (42) | 123 (56) | 202 (92) | 202 (92) |
| 4" | 132 (60) | 177 (80) | 305 (138) | 305 (138) |
| 6" | 207 (94) | 262 (119) | 455 (206) | 455 (206) |
| 8" | 282 (128) | 367 (166) | 719 (326) | 719 (326) |
| 10" | 498 (226) | 633 (287) | 1166 (529) | 1166 (529) |
| 12" | 742 (337) | 942 (427) | 1533 (695) | 1533 (695) |